

# TUBE LINE

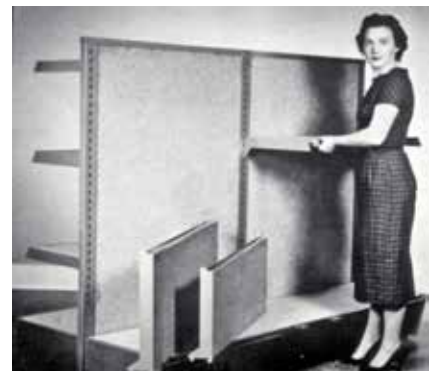

**madix**  
INNOVATION ON DISPLAY



“You either have quality or you don’t,”  
— Sherif Sharawi



## A GUARANTEE YOU CAN TRUST

Both **domestically manufactured** and **imported products** go through the same standards of testing to assure that what we sell is **Madix Certified Quality**.



### Design

Our 67+ years of experience working with retailers and brands has taught us to not overengineer products, which can lead to bulkiness and costliness.



### Testing

All imported and domestically manufactured parts undergo the same rigorous testing against aesthetics, durability, and safety.



### Packaging

Madix always protects our fixtures for delivery while eliminating any unnecessary packaging, resulting in store installations that are easy to manage and cost effective.

Information obtained through in-house testing of various import products designed to be interchangeable with major store fixture manufacturers.

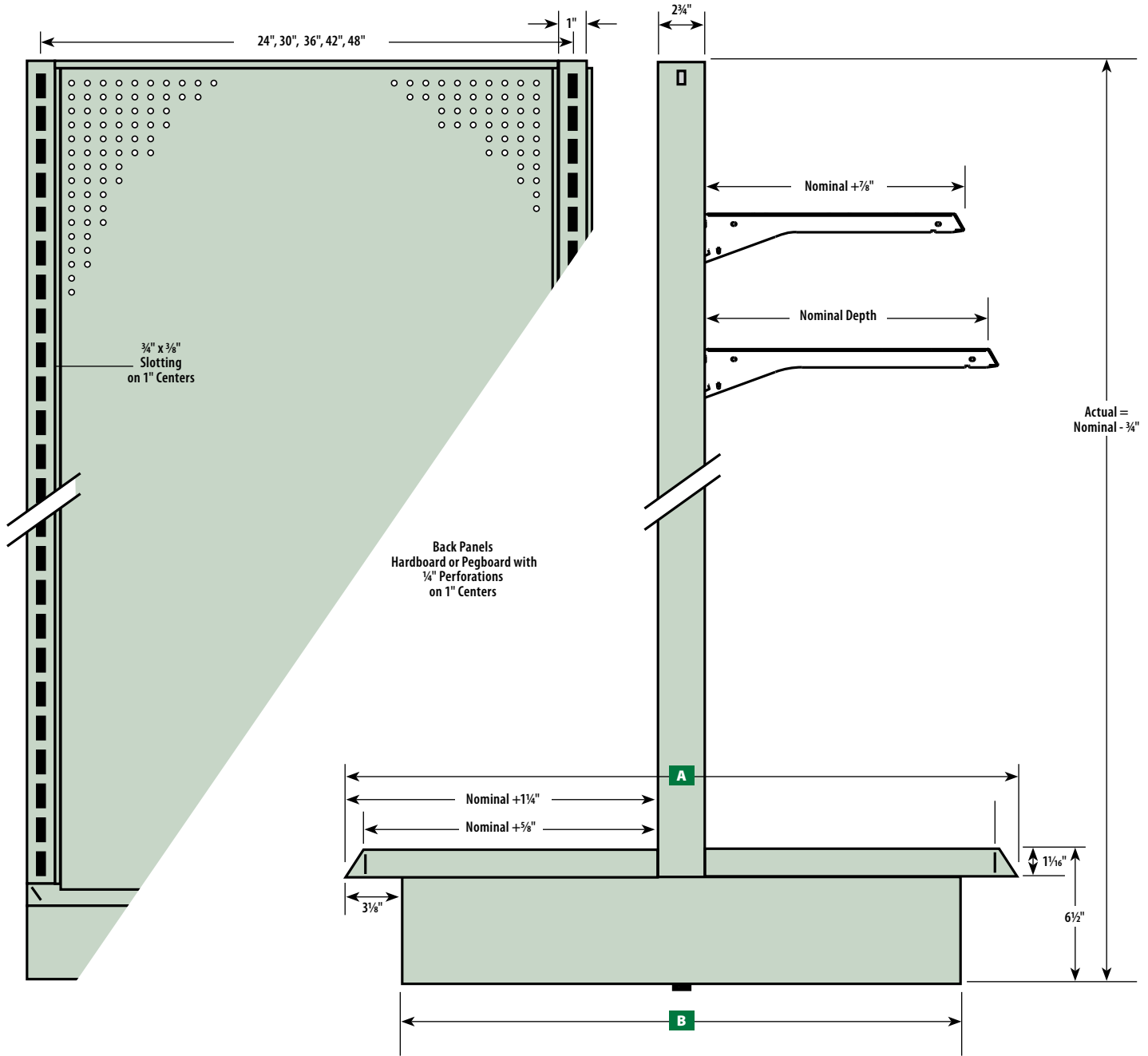

- Nominal Upright Heights  
36" through 120" in 6" increments  
(914 mm-3048 mm in 152 mm increments)
- Nominal Side Deck Depths  
8" through 36" in 2" increments  
(203 mm-914 mm in 51 mm increments)
- Nominal Metal Shelf Depths  
8" through 24" in 2" increments  
(203 mm-610 mm in 51 mm increments)

**A** Nominal Side Deck Depth  
plus  
Nominal Side Deck Depth  
plus  
5 1/4" (133 mm)  
equals  
Nominal Counter Width

Ex: 22" + 22" + 5 1/4" = 49 1/4"  
(559 mm+559 mm+133 mm=1251 mm)

**B** Nominal Side Deck Depth  
plus  
Nominal Side Deck Depth  
minus  
1" (25 mm)  
equals  
Nominal Base Width

Ex: 22 + 22 - 1 = 43  
(559 mm+559 mm+25 mm=1092 mm)

**NOTE!**  
Dimensions are + or - 1/8"  
(3 mm) and are subject to  
change without notice.

## Tube Line Counter-Single Back

Description	Part Number
<b>A</b> Tube Line Single Back Upright, No Levelers, End	TLCUNL1E(NH)(LS)(RS)7
<b>B</b> Tube Line Single Back Upright, No Levelers, Int.	TLCUNL1I(NH)(LS)(RS)7
<b>C</b> Tube Line Kickplate, Open Front	TLCKOF(NW)
<b>D</b> Tube Line End Trim	TLCBEOP (LS)(RS)7
<b>E</b> Tube Line Top Cap, Single Back	TLTC1(NW)
<b>F</b> Tube Line Side Deck	TLSDD(NW)(ND)
<b>G</b> Tube Line Single Back, Painted Two Sides	TLB1(NW)(NH)7(OPT)

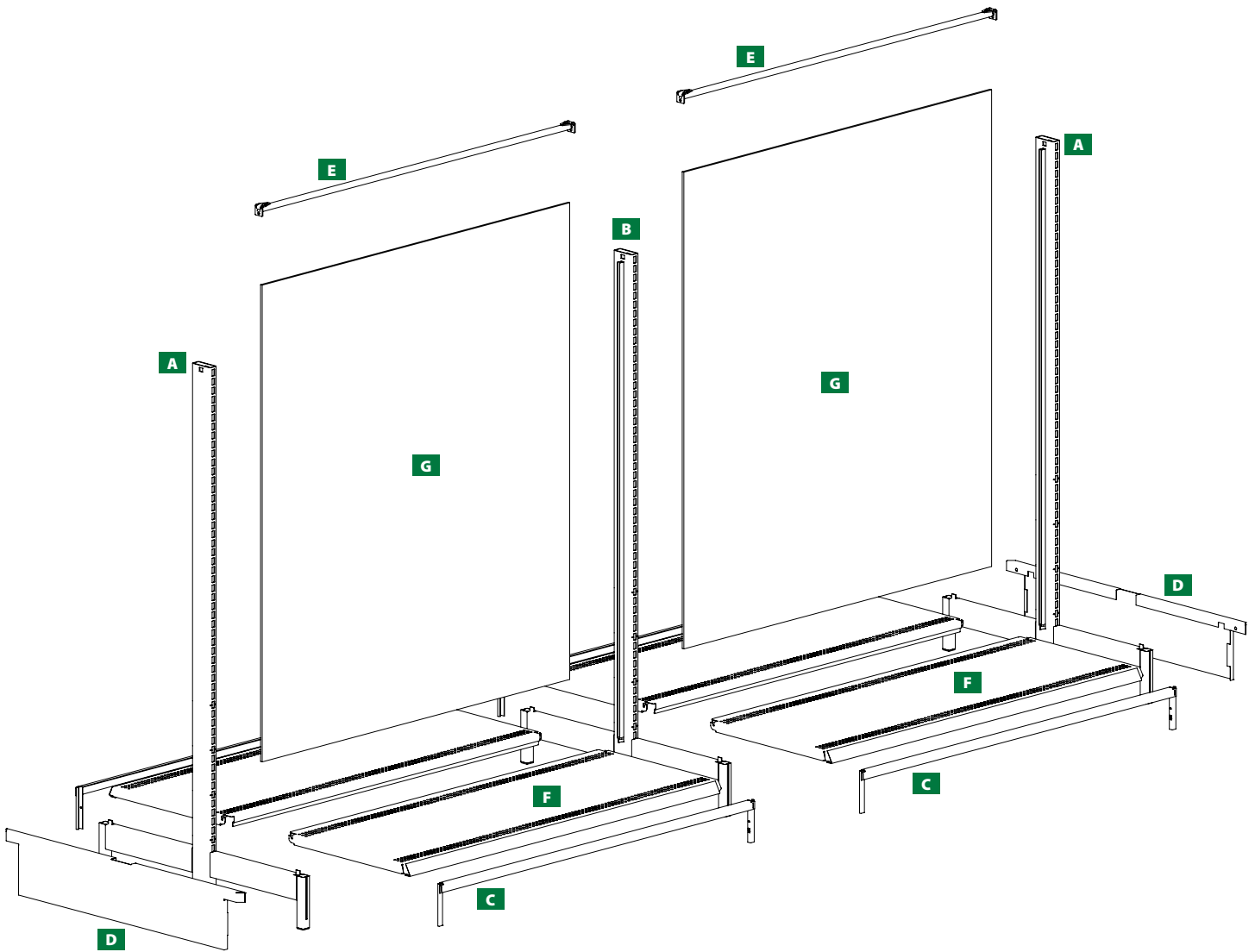

## Tube Line Half Counter-Single Back

Description	Part Number
<b>A</b> Tube Line Single Back Half Upright, No Levelers, Left	TLHUNL1L(NH)(ND)7
<b>B</b> Tube Line Single Back Half Upright, No Levelers, Right	TLHUNL1R(NH)(ND)7
<b>C</b> Tube Line Single Back Half Upright, No Levelers, Int.	TLHUNL1I(NH)(ND)7
<b>D</b> Tube Line Kickplate, Open Front	TLCKOF(NW)
<b>E</b> Tube Line Kickplate, Rear	TLCKR(NW)7
<b>F</b> Tube Line End Trim, Left-Hand	TLHBEOPL(NH)7L
<b>G</b> Tube Line End Trim, Right-Hand	TLHBEOPR(NH)7R
<b>H</b> Tube Line Top Cap Single Back	TLTC1(NW)
<b>I</b> Tube Line Side Deck	TLSD(NW)(ND)
<b>J</b> Tube Line Single Back, Painted Two Sides	TLB1(NW)(NH)7(I)
<b>K</b> Seismic Floor Anchors, Regular-Duty	SFA-RD-1
<b>L</b> Seismic Anchor Bolts	SFA-EB-1

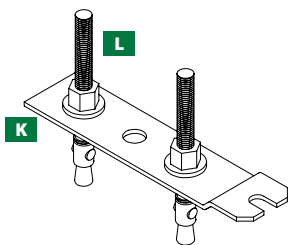
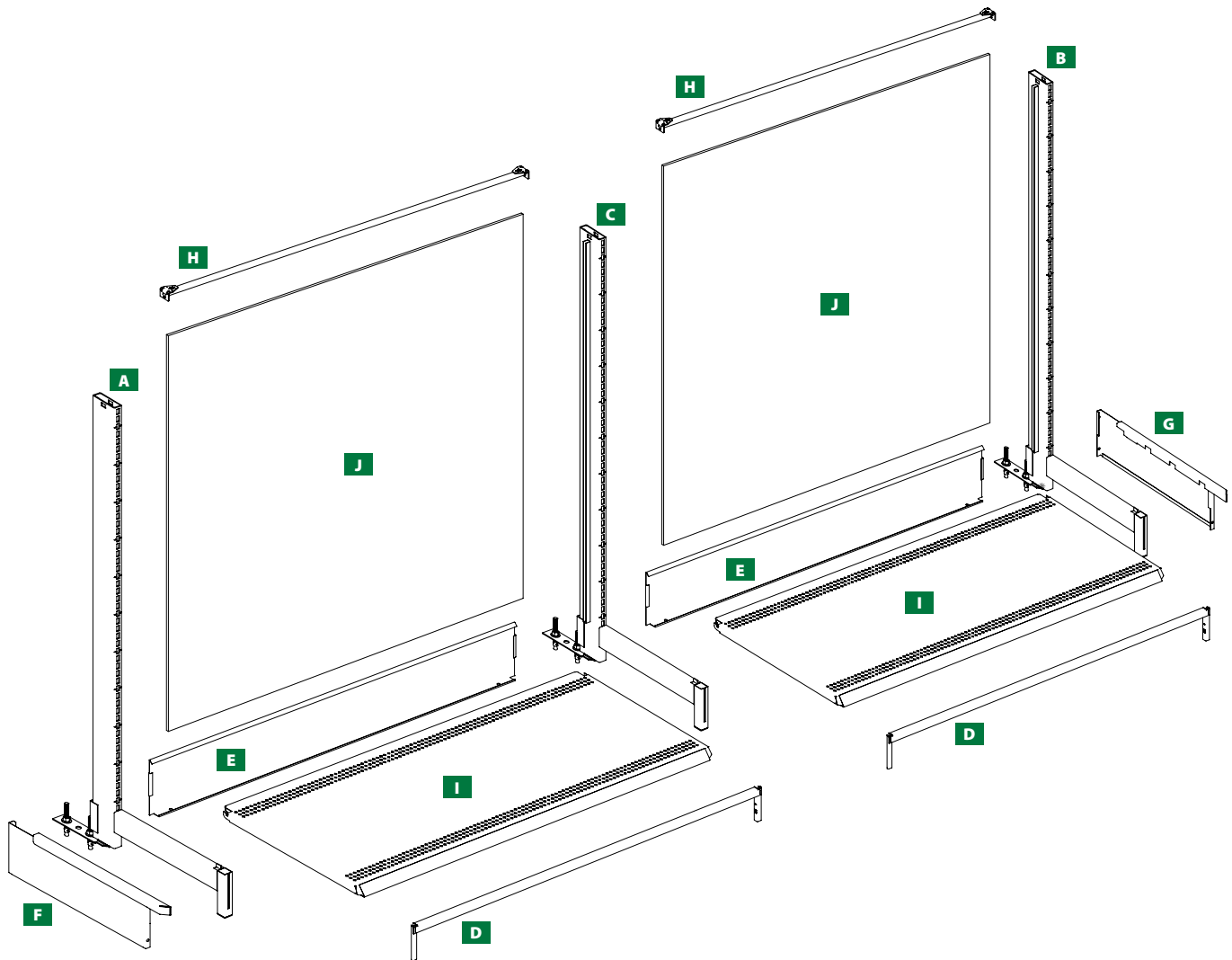

Enlargement of Seismic Floor Anchors & Bolts

## Tube Line Counter-Double Back

Description	Part Number
<b>A</b> Tube Line Single Back Upright, No Levelers, End	TLCUNL1E(NH)(LS)(RS)7
<b>B</b> Tube Line Single Back Upright, No Levelers, Int.	TLCUNL1I(NH)(LS)(RS)7
<b>C</b> Tube Line Kickplate, Open Front	TLCKOF(NW)
<b>D</b> Tube Line End Trim	TLCBEOP(LS)(RS)7
<b>E</b> Tube Line Top Cap, Double Back	TLTC2(NW)
<b>F</b> Tube Line Side Deck	TLSDD(NW)(ND)
<b>G</b> Tube Line Single Back, Painted One Side	TLB3(NW)(NH)7(OPT)
<b>H</b> Tube Line Double Back Bottom Spanner	TLBS2(NW)
<b>I</b> Tube Line Plastic Panel Retainer	TLBTS7-(NH)-(OPT)

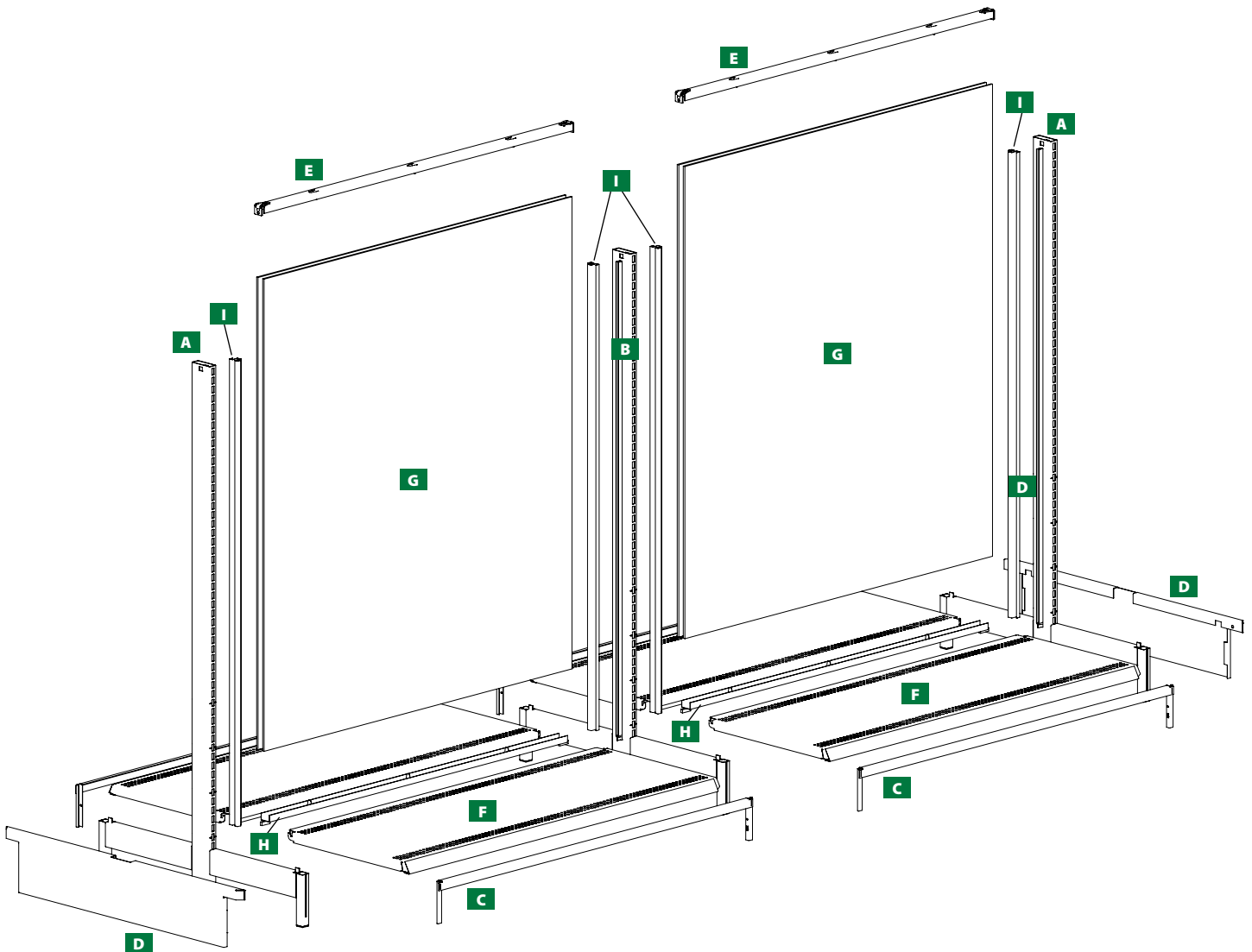

## Tube Line Half Counter-Double Back

Description	Part Number
<b>A</b> Tube Line Single Back Half Upright, No Levelers, Left	TLHUNL1L(NH)(ND)7
<b>B</b> Tube Line Single Back Half Upright, No Levelers, Right	TLHUNL1R(NH)(ND)7
<b>C</b> Tube Line Single Back Half Upright, No Levelers, Int.	TLHUNL1I(NH)(ND)7
<b>D</b> Tube Line Kickplate, Open Front	TLCKOF(NW)
<b>E</b> Tube Line Kickplate, Rear	TLCKR(NW)7
<b>F</b> Tube Line End Trim, Left-Hand	TLHBEOP(ND)7L
<b>G</b> Tube Line End Trim, Right-Hand	TLHBEOP(ND)7R
<b>H</b> Tube Line Top Cap Single Back	TLTC2(NW)
<b>I</b> Tube Line Side Deck	TLSD7(NW)(ND)
<b>J</b> Tube Line Single Back, Painted One Side	TLB3(NW)(NH)7(OPT)
<b>K</b> Tube Line Back Bottom Spanner	TLBS2(NW)
<b>L</b> Tube Line Plastic Panel Retainer	TLBTS7-(NH)-(OPT)
<b>M</b> Seismic Floor Anchors, Regular-Duty	SFA-RD-1
<b>N</b> Seismic Anchor Bolts	SFA-EB-1

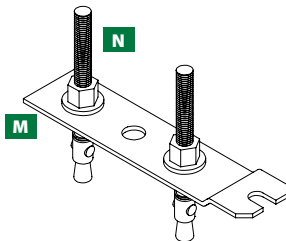
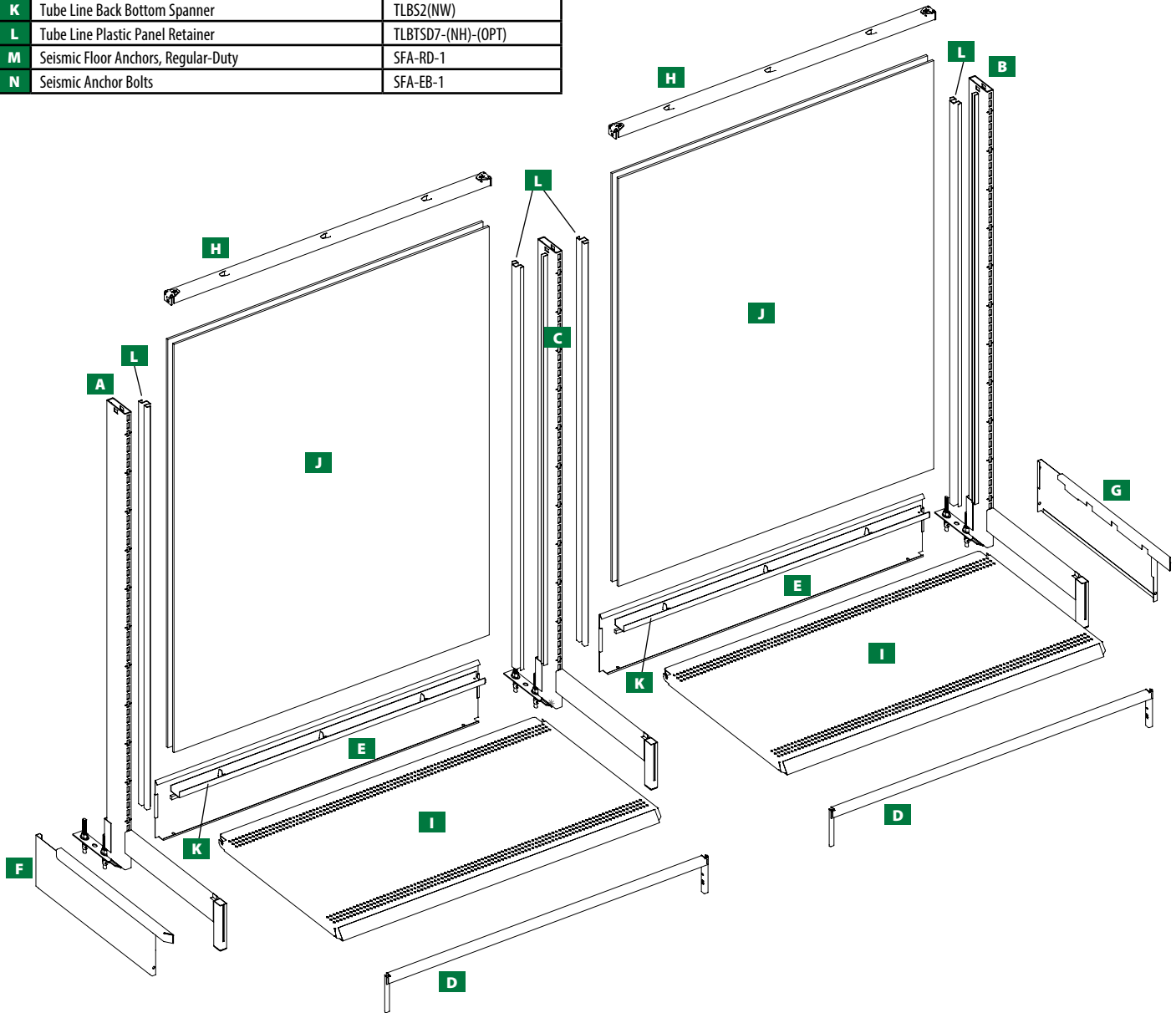

Enlargement of Seismic Floor Anchors & Bolts

# Tube Line

## Tube Line Counter Uprights- Single Back End and Intermediate, No Levelers

- Single Back configuration to be used in making a two-sided display
- All Counter Uprights are 1" x 2¾" (25 mm x 70 mm) tubing

### TLCUNL1(OPT)(NH)(LS)(RS)7

- TLCU .... Tube Line Counter Upright
- NL1 .... No Levelers, Single Back
- OPT .... E=End  
I=Intermediate
- NH .... Nominal Height 36" to 96" in 6" increments  
(914 mm to 2438 mm in 152 mm increments)
- LS .... Left Side Base Size 8" to 36" in 2" increments  
(203 mm to 914 mm in 51 mm increments)
- RS .... Right Side Base Size 8" to 36" in 2" increments  
(203 mm to 914 mm in 51 mm increments)
- 7 .... 7" High Base (178 mm)

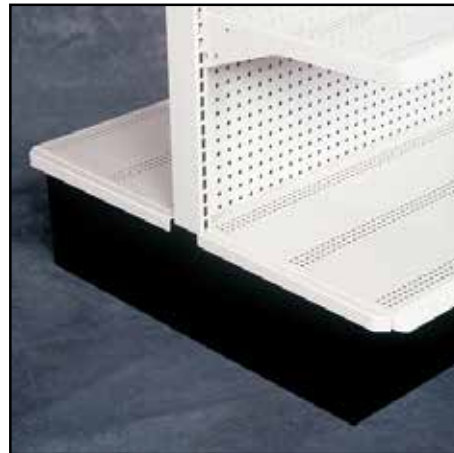
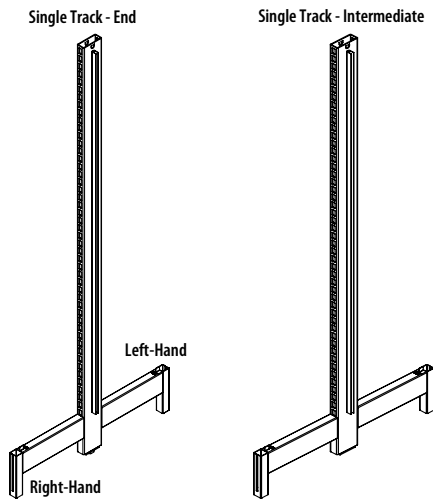

## Tube Line Half Counter Uprights- Single Back End, No Levelers

- Used where a freestanding single sided display is desired
- All Half Counter Uprights are 1" x 2¾" (25 mm x 70 mm) tubing

### TLHUNL1(OPT)(NH)(ND)7

- TLHU .... Tube Line Half Counter Upright
- NL1 .... No Levelers, Single Back
- OPT .... I=Intermediate  
R=Right-hand  
L=Left-hand
- NH .... Nominal Height 36" to 96" in 6" increments  
(914 mm to 2438 mm in 152 mm increments)
- ND .... Nominal Depth Size 8" to 36" in 2" increments  
(203 mm to 914 mm in 51 mm increments)
- 7 .... 7" High Base (178 mm)

**NOTE!**  
It is recommended that these be anchored to prevent tipping if not pushed up against a wall

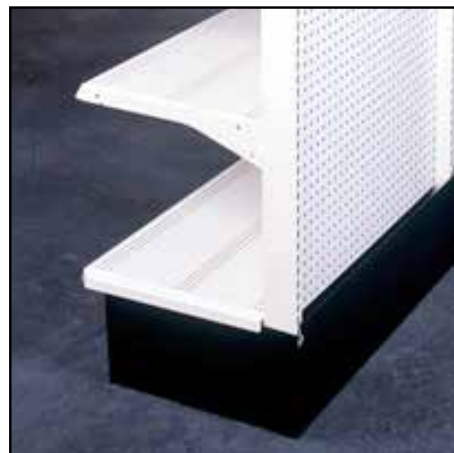
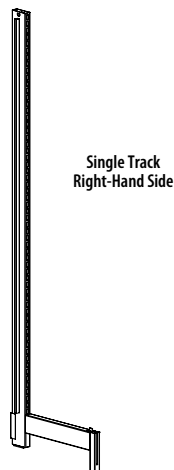



### Tube Line Counter Kickplate Open Frame

- Open Front Kickplate designed to permit cleaning under shelving as required by some local codes
- Standard finishes: Chocolate or Black

#### TLCKOF(NW)

TLCKOF .... Tube Line Counter Kickplate Open Frame  
 NW .... Nominal Width 24" to 48" in 6" increments  
 (610 mm to 1219 mm in 152 mm increments)

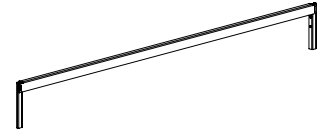

### Tube Line Counter Base End One Piece End Trim

- Standard finishes: Chocolate or Black

#### TLCBEOP(LS)(RS)7

TLCBE .... Tube Line Counter Base End  
 OP .... One Piece End Trim  
 LS .... 10" to 30" (254 mm to 762 mm)  
 RS .... 10" to 30" (254 mm to 762 mm)  
 7 .... Deck Height 7" (178 mm)

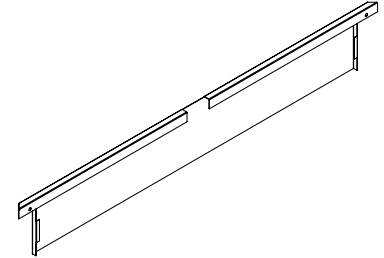

### Tube Line Half Counter Base End Trim One Piece

- Used at both ends of half counter run
- Order as pairs
- Standard finishes: Chocolate or Black

#### TLHBEO(ND)7(OPT)

TLH .... Tube Line Half Counter  
 BEO .... Base End Trim One Piece  
 ND .... Nominal Depth 08" to 30" in 2" increments  
 (203 mm to 762 mm in 51 mm increments)  
 7 .... 7" High Base (178 mm)  
 OPT .... L=Left-Hand  
 R=Right-Hand  
 Blank=Pair

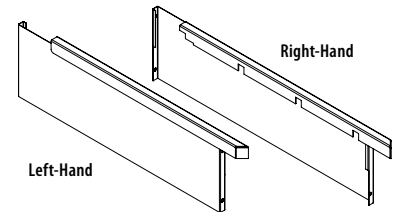

### Tube Line Counter Kickplate

- Used with either Counter or Half Counter sections, providing a finished appearance to section
- Standard finishes: Chocolate or Black

#### TLCK(NW)7

TLCK .... Tube Line Counter Kickplate  
 NW .... Nominal Width 24" to 48" in 6" increments  
 (610 mm to 1219 mm in 152 mm increments)  
 7 .... 7" High Base (178 mm)

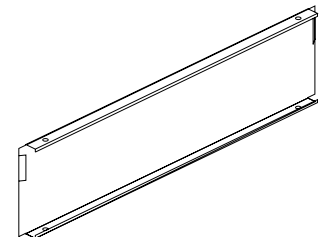

### Tube Line Counter Kickplate Rear

- Used to close lower back portion of Half Counter section
- Standard finishes: Chocolate or Black

#### TLCKR(NW)7

TLCKR .... Tube Line Counter Kickplate  
 NW .... Nominal Width 24" to 48" in 6" increments  
 (610 mm to 1219 mm in 152 mm increments)  
 7 .... 7" High Base (178 mm)

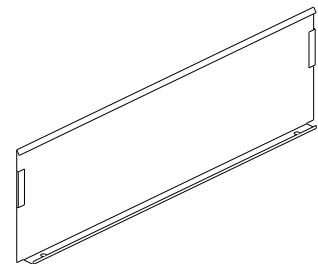

## Tube Line Top Cap, Single Back

- Standard finishes: Chocolate or Black

### TLTC1(NW)

TLTC1 .... Tube Line Counter Base End  
NW .... One Piece End Trim

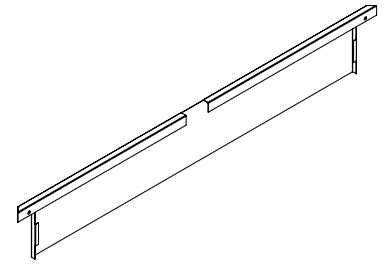

## Tube Line, Double Top Cap

- Secures uprights at equal spacing, traps back panels and trims the top of section

### TLTC2(OPT)(NW)

TLTC .... Tube Line Top Cap  
2 .... Double Back  
NW .... Nominal Width 24" to 48" in 6" increments  
(610 mm to 1219 mm in 152 mm increments)

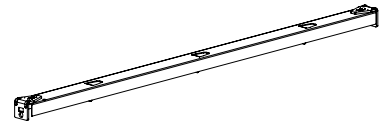

## Tube Line Bottom Stretcher, Double Back

- No Bottom Stretcher is required in Single Track System

### TLBS2(NW)

TLBS .... Tube Line Bottom Stretcher  
2 .... Double Back  
NW .... Nominal Width 24" to 48" in 6" increments  
(610 mm to 1219 mm in 152 mm increments)

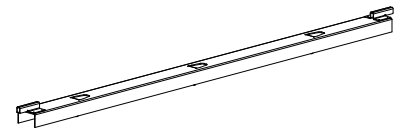

## Tube Line Back Single to Double Track

- Sized to fit only the Double Track Extension
- Available in both Hardboard or Pegboard

### TLBTSD7-(NH)-(COLOR)

TLBTSD .... Tube Line Back Track Single to Double  
7 .... 7" High (178 mm)  
NH .... Nominal Height 24" to 96" in 6" increments  
(610 mm to 2438 mm in 152 mm increments)  
COLOR .... CL= Clear



## Seismic Floor Anchor & Bolt

- Required to anchor Half Counter to floor when the Half Counter is not against wall
- Expansion Bolts must be ordered separately
- Galvanized finish only

### SFA-RD-1

SFA .... Tube Line Seismic Floor Anchor  
RD .... Regular-Duty  
1 .... 1=1 Pack  
25=25 Pack

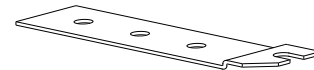

### SFA-EB50

SFA .... Tube Line Seismic Floor Anchor  
EB .... Expansion Bolt  
50 .... 50 Pack

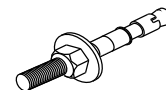

## Tube Line Upright Cap with Slot

- Metal cap used to provide a finished appearance to the uprights

### TLUCS

TLUCS .... Tube Line Upright Cap with Slot

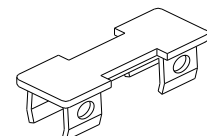

### Tube Line Single Back

- Available in both Hardboard, Pegboard, Laminate or Mirror Mylar

#### TLB1(NW)(NH)7(TYPE)(COLOR)X2

TLCK .... Tube Line Single Back  
 NW .... Nominal Width 24" to 48" in 6" increments  
 (610 mm to 1219 mm in 152 mm increments)  
 NH .... Nominal Height 48" to 96" in 6" increments  
 (1219 mm to 2438 mm in 152 mm increments)  
 7 .... 7" High Base (178 mm)  
 TYPE .... P=Pegboard  
           H=Hardboard  
           CP=Clear Plex ¼" (6 mm)  
 COLOR .... Paint or Laminate Color Code  
           M=Mirror Mylar One Side  
           M2S=Mirror Mylar Two Sides  
 X2 .... X2=Finished Two Sides  
        Blank=Finished One Side

### Tube Line Triple Back

- Available in both Hardboard, Pegboard, Laminate or Mirror Mylar

#### TLB3(NW)(NH)7(TYPE)-(COLOR)X2

TLCK .... Tube Line Triple Back  
 NW .... Nominal Width 24" to 48" in 6" increments  
 (610 mm to 1219 mm in 152 mm increments)  
 NH .... Nominal Height 48" to 96" in 6" increments  
 (1219 mm to 2438 mm in 152 mm increments)  
 7 .... 7" High Base (178 mm)  
 TYPE .... P=Pegboard  
           H=Hardboard  
           PM=Pegboard, Mirror Mylar  
           HM=Hardboard, Mirror Mylar  
           HL=Hardboard, Laminated Two Sides  
 COLOR .... Paint or Laminate Color Code  
 X2 .... X2=Finished Two Sides  
        Blank=Finished One Side

### Tube Line Side Deck

- Each Base Deck has three rows of diamond perforations, spaced ½" (13 mm) OC at front and back of shelf

#### TLSD(NW)(ND)

TLSDDD .... Tube Line Side Deck  
 NW .... Nominal Width 24", 30", 36", 48"  
 (610 mm, 762 mm, 914 mm, 1219 mm)  
 ND .... Nominal Depth 8" to 36" in 2" Increments  
 (203 mm to 914 mm in 51 mm Increments)

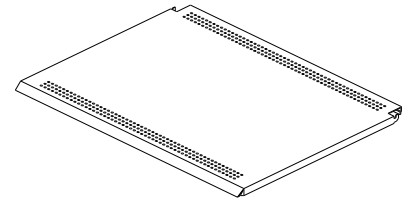

## Tube Line Metal Shelf

- Available with or without 1/2" OC diamond perforations
- Brackets are three position: flat, 15° downslope and 12° up tilt
- Load capacity 400 lbs

### TLMS(OPT)(NW)(ND)-(TAG)(COLOR)

TLMS .... Tube Line Metal Shelf  
 OPT .... D=Diamond Perforated  
           NP=Non-Perforated  
 NW .... Nominal Width 18" to 48" in 6" increments  
           (457 mm to 1219 mm in 152 mm increments)  
 ND .... Nominal Depth 08" to 24" in 2" increments  
           (203 mm to 610 mm in 51 mm increments)

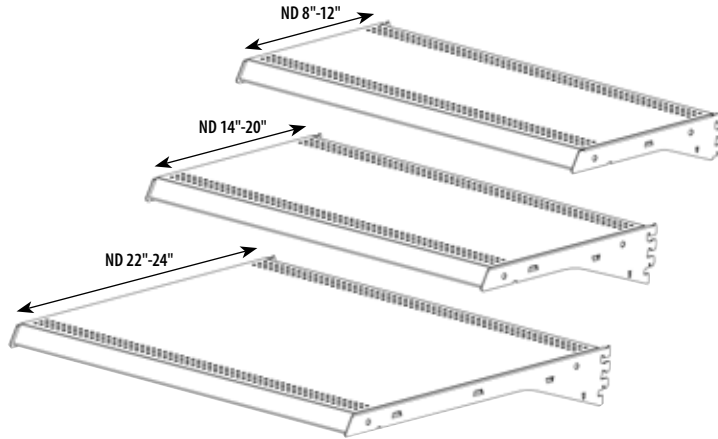

## Tube Line Feature End Deck

- Used with the Feature End Frame to make End Cap when a base is desired
- Features the same diamond perforation patterns as Tube Line Metal Shelves

### A Tube Line Feature End Deck Shelf with Double Perforation

#### TLFEDSD(ND)(LS)(RS)

TLFEDSD .... Tube Line Feature End Deck Shelf with Double Perforation  
 ND..... Nominal Depth 10" to 40" in 2" increments  
           (254 mm to 1016 mm in 51 mm increments)  
 LS..... Left Side 10" to 22" in 2" increments  
           (254 mm to 559 mm in 51 mm increments)  
 RS..... Right Side 10" to 22" in 2" increments  
           (254 mm to 559 mm in 51 mm increments)

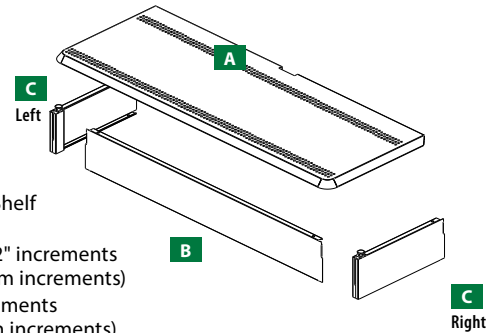

### B Tube Line Feature End Deck Kickplate

- Standard finishes: Chocolate or Black

#### TLFEDK(LS)(RS)7

TLFEDK..... Tube Line Feature End Deck Kickplate  
 LS..... Left Side 10" to 24" in 2" increments  
           (254 mm to 610 mm in 51 mm increments)  
 RS..... Right Side 10" to 24" in 2" increments  
           (254 mm to 610 mm in 51 mm increments)  
 7..... 7" High Base (178 mm)

### C Tube Line Feature End Side Rail Base

- Standard finishes: Chocolate or Black

#### TLFEDR(ND)7(OPT)

TLFEDR..... Tube Line Feature End Deck Side Rail Base  
 ND..... Nominal Depth 12" to 24" in 2" increments  
           (254 mm to 610 mm in 51 mm increments)  
 7..... 7" High Base (178 mm)  
 OPT..... L=Left  
           R=Right

### Tube Line Feature End Frame

- Designed to be used at the end of counter run or end cap
- Can be used with or without the Feature End Deck [TLFEDD(ND)(LS)(RS)7]
- Order Tube Line Metal Shelves, sold separately, [TLMSD(NW)(ND)] same width as Feature End Frame if required
- Tube Line End Frame with no slots can be used anywhere the Feature End Frame is used when shelves are not needed
- Works well as an End Panel to give a finished look when shelving capabilities are not required
- If ordered with back painted two sides, order the same color on both sides

### TLFEFCF(OPT1)(NW)(NH)7(OPT2)

- TLFEFCF.... Tube Line Feature End Frame  
Single Track and Back in Front
- OPT1 .... Blank=No Keyslot  
K=Keyslot
- NW .... Nominal Width 24" to 48" in 6" increments  
(610 mm to 1219 mm in 152 mm increments)
- NH .... Nominal Height 48" to 90" in 6" increments  
(1219 mm to 2286 mm in 152 mm increments)
- 7 .... 7" High Base (178 mm)
- OPT2 .... P= Pegboard  
H= Hardboard  
Blank=No Back

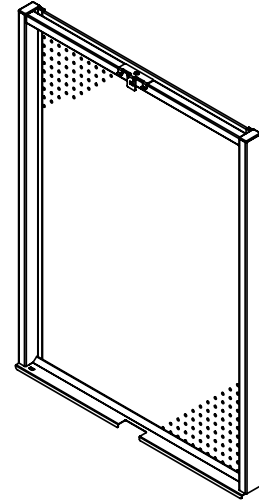

### Tube Line Counter Extension without Panel Retainers

- Used to extend height of Single Track End and Intermediate Uprights when no Back Panels are used
- 1" x 2¾" (25 mm x 70 mm) tubing

### TLCE(NH)

- TLCE .... Tube Line Counter Extension Upright
- NH .... Nominal Height 6" to 54" in 6" increments  
(152 mm to 1372 mm in 152 mm increments)



### Tube Line Counter Extension Upright Single Track, End and Intermediate

- Used to extend height of Single Track End and Intermediate Uprights when no Back Panels are used
- 1" x 2¾" (25 mm x 70 mm) tubing

### TLCE1(OPT)(NH)

- TLCE .... Tube Line Counter Extension Upright
- 1 .... Single Track
- OPT .... E=End  
I=Intermediate
- NH .... Nominal Height 6" to 54" in 6" increments  
(152 mm to 1372 mm in 152 mm increments)

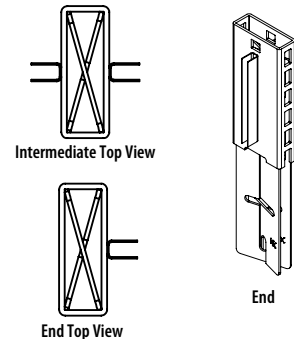

### Tube Line Upright Attachment

- Mounts Tube Line to either wood furring strips or masonry walls
- TWUAK contains:
  - 2 - ¼" - 20 x 4" TAPCON
  - 2 - ¼" - 20 CounterSink Washers
  - 1 kit required per upright
- TLWUAKE contains:
  - 1 - ¼" - 20 x 4" TAPCON
  - 1 - ¼" - 20 CounterSink Washer
  - 1 kit required per extension

### TLWUAK(OPT)

- TLWUAK.... Tube Line Wall Upright Kit
- OPT .... Blank=Upright Attachment Kit  
E=Extension Upright Attachment Kit

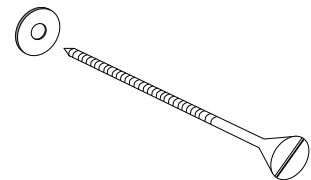

**Prices** All prices are subject to change without notice. Every effort will be made to give advance notice of any increase through notification from the home office. The customer will receive an acknowledgement showing prevailing prices at the time the order is processed. State or other sales or use taxes, freight and surcharges will be charged when applicable. Freight quotes may be provided based upon information available at time of quote, but are not guaranteed. Active freight charges will be billed if applicable. When market conditions dictate, a surcharge may be implemented. All quotations automatically expire at the end of 30 days.

**Terms** Cash in advance prior to production or net 30 days if open account status is approved by Madix Credit Department. MasterCard, Visa, and American Express are accepted.

**Acceptance** All orders, contracts, and agreements are subject to Madix's acceptance and approval. Madix shall not be liable for any delay in the performance of any order, contract, in the delivery of any goods, or for any damages resulting from such delay, when such delay is directly or indirectly caused by or due to fire, flood, accident, riot, act of God, war, governmental decree or order, strike, labor difficulties, shortage of labor, fuel, power, material or supplies, transportation delay or any other delay or causes (whether or not similar to any of those herein before specified) beyond our reasonable control. Order acceptance will be per the conditions and terms outlined in Madix's acknowledgement. Mailing of the acknowledgement will signify Madix's acceptance of the order.

**Minimum Charge** Orders are subject to a minimum charge of \$50.00 net (merchandise only) per shipping destination.

**Changes and Cancellations** Customer requested changes and cancellations are subject to approval by Madix. Every reasonable effort will be made to accommodate these requests without additional cost to the customer. Any manufacturing or engineering costs incurred will be charged to the customer. Orders produced and delayed for more than one week may incur charges for demurrage, unloading, or other storage costs. Madix will advise customers of the estimated charges at the time changes or cancellations are made.

**Shipments** Method and route of shipment are at Madix's discretion unless Madix is furnished with complete shipping instructions at least ten (10) days before the scheduled shipping date. Freight is FOB/EXW Madix shipping point.

**Freight Claims** For common carrier shipments, claims must be made directly with the carrier by the recipient. Listed are the types of losses which may occur, and your responsibility in handling them:

**Loss of Freight:** It is the receiver's responsibility to count the freight at the time of delivery. Any exception must be noted on the carrier's delivery receipt at time of delivery.

**Damage of Freight:** As with a loss of freight, damage of freight must be noted on the carrier's delivery receipt at the time of delivery. It is the receiver's responsibility to make sure that the freight is inspected for visible damage and that the number of pieces damaged is marked on the carrier's delivery receipt. Failure to note visible damage at the time of delivery will result in non-payment of a damage freight claim. Salvage must be held for the carrier.

**Concealed Damage:** If goods are received in apparently good condition but there is concealed damage, it is the customer's responsibility to contact your Madix Service Representative within 15 calendar days from delivery. Customer must keep the product and the packaging so that an inspection may be conducted by the carrier. Failure to handle a concealed damage claim in this manner could greatly reduce the amount recovered from the carrier.

**Returned Goods** Returned Goods requests must be submitted to Madix, Inc. within 60 days after receipt of product. Authorization must be in writing on Madix's RGA (Return Goods Authorization) form. Goods must be received within 30 days of RGA issue date for credit. Customer is responsible for delivery of authorized returns to Madix designated location in condition originally received. Only Code A products finished in returnable colors as indicated on the finish policy pages will be considered for return, and only items in unused, in resalable condition, and in the original packaging. No special size, color, or specially manufactured parts or products are eligible for return unless sent to the customer as the result of an error by Madix. Only merchandise listed on the RGA will be accepted for conditional return. Credit will not be issued for that portion of merchandise that is not considered resalable. A handling and restocking charge of 25% of the invoice price will be charged for all approved returns. Submit requests to your Madix Sales Representative or Customer Service Department prior to returning any merchandise. All returns must be have the customer name and Madix RGA number prominently displayed on each package. Product to be shipped prepaid at customer's expense unless prior approval has been received from an authorized Madix Representative.

**Warranty** We warrant to the original purchaser that all products manufactured by Madix are free from defects in material and workmanship. This warranty is invalid if products or parts are modified or used in a manner other than the intended purpose. Our obligation under this warranty is limited to repairing or replacing of any part or parts which shall, within one (1) year after delivery to the original purchaser, be demonstrated to be defective under normal use and service. This warranty is in lieu of all other warranties, expressed or implied, and of all other obligations or liabilities of any kind on Madix's part, and no modification of this warranty shall be valid or binding unless in writing and signed by an officer of Madix, Inc.

**Production** Madix fixtures are manufactured utilizing the most current technology of highly automated systems with process control techniques. Skilled craftsmanship, combined with automatic presses, roll forming machines, multi-spot welders, conveyers, finishing equipment and thorough inspections produce store fixtures of the highest quality.

**Upright** Carefully engineered of heavy gauge, high quality steel components, the UPRIGHT is slotted one inch on center for maximum flexibility, shelf adjustability and use of available space. Standard heights range from 36" through 96" with built-in leveler. For the finishing touch at the end of the shelving run, the snap-on UPRIGHT END COVER is made of durable, scuff and impact resistant plastic or heavy gauge metal. The UPRIGHT CAP, made of high impact plastic, has provision for a sign holder.

**Base Shoe** The five inch low BASE SHOE features exclusive "I" beam design, engineered of projection welded high strength steel parts insuring maximum load capacity. Snaps securely into upright with leveler and electrical access allowing for quick error free installation. For the finished look, the one piece slip on BASE END COVER is made with a high impact plastic nose reinforcement to protect base shelf tag molding.

**Spanners** Snap-in support SPANNERS keep uprights at equal spacing and hold the back panels rigid. Each spanner has knockouts for electrical access and telescoping uprights.

**Back Panels** High density hardboard BACKS fit flush to the face of the upright. A wide variety of finishes include solid, pegboard, and wood grain in a wide assortment of optional colors. Mirrors and open backs are also available.

**Kickplate** Fully floating feature of kickplate allows flush fit against uneven floors, snaps in and out without disturbing base shelf for easy cleaning. Convenient knockout accommodates electrical access.

**Base and Upper Shelves** Steel base shelves feature lock tabs to insure quick installation and precision alignment. A double row of 1/4" inch perforations on the front and rear edge makes any form for binning possible. Slim bracket, high tensile design with flat or 15 degree downslope upper shelf positions allow for maximum merchandise visibility. Integrally formed price tag molding accommodates 11/4" tag. Upper shelves available in 8", 10", 12", 14", 16", 20", 22", 24", 26", 28", and 30" depths. Base shelves available in 12", 14", 16", 18", 20", 22" 24", 26", 28" and 30" depths.

**Shelf Loading** The recommended load capacity for upper shelves is based on evenly distributed weight. Capacities are reduced by 35% when front half is loaded and reflect rated maximum load. Load capacities are shown in the General Information Section under Shelf Loading.

**Baked Enamel, Powder Coat Finishes** All metal parts are finished with a specially formulated high solids or powder which are electrostatically bonded in a unique multi-stage process, to insure the highest quality finish. Aerosol cans of Touch-up paint are available in Madix's standard and optional colors. FAA regulations prohibit the shipment of this product by air or in export containers by air or ocean to countries outside the United States.

**Product Maintenance** When necessary to clean Madix shelving, use a non-abrasive mild detergent and warm water, followed by thorough drying. The use of a cloth made of a soft white cotton material is strongly recommended. The use of cleaning products that contain abrasive, bleach, or strong solvents, such as ketones, ethers, etc. will result in damage to the finish. The damage is most severe when these harsh cleaning agents are used on colors which contain leafing aluminum pigment such as powder chrome, silver vein, and other "vein" type finishes. The aluminum in these coatings resides at the surface of the finish and is therefore susceptible to damage by the harsh cleaning agents. As an alternative to the mild detergent, cleaners with ingredients similar to those found in products such as 409, Fantastik, and Simple Green can be used. Caution! Cleaners having ingredients similar to those found in Ajax, Borax, Comet, etc. should be avoided as finish damage could result.

**Codes** In your planning stage, consult with local municipal engineers to determine what codes and restrictions will be applicable in the locations where the shelving will be used. Codes may include: state, local, fire, building, and health and safety codes. Seismic requirements may apply in some locations. For example, in most locations fire codes state that fixtures need to be at least 18 inches below the sprinklers.

**Shelving Selection** Take into consideration the load that is expected not only on each shelf but also on the unit as a whole. Take into account the upright capacity. Refer to the load capacity information that is in the Madix Standard Catalog. Madix shelves are rated using an evenly distributed load. Do not install shelves or accessories that extend beyond the depth of the Base Shelves. Consider making the Base Shelves and low height fixtures a contrasting color from the floor's color to prevent potential tripping hazards. Do not use Madix parts or accessories for any purpose other than originally intended by Madix.

**Shelving Installation** Initial installation or relocation of Madix shelving should be supervised by qualified personnel. Madix products should be installed according to Madix's specifications. Madix's installation sequence must be followed for assembly and leveling. An improperly installed store fixture has a poor appearance and may cause a dangerous condition. Be especially careful when leveling fixtures with offset loads in which one side of the fixture has a considerably heavier load than the other side. Dismantling and reassembling used Madix shelving can be dangerous if the installers who are doing the work leave out parts, use damaged parts, or do not reassemble the product by Madix's specifications. Do not alter, modify, or structurally change any shelving component. Do not move assembled shelving. Only parts and accessories that are produced and supplied by Madix are covered by the Madix warranty. Do not assemble Madix fixtures with parts from other manufacturers. Under no circumstances should you use damaged parts. When assembling Gondola/Wall Shelving, install Kickplates to protect the Base Shoes from floor cleaning equipment and to offset the possible bumping and misalignment of the shelving runs. Do not install shelves or accessories on the sides of wall sections or any section that is not supported by Base Shoes. Use caution when handling and transporting shelving parts. Be careful when cutting shrink wrap from pallets because the shelving parts can dislodge from the wrap and fall. Cut the wrap gradually from the top, only as much as you need to remove the product from the top. Two common hazards while installing store fixtures are: employees hurting themselves with improper types of box cutters and employees putting boxes on the floor and then tripping over them.

**Anchoring and Floors** Depending on code requirements and Madix's specifications, some products must be anchored to the walls and/or floors. Do not lean tall or heavy objects against unanchored shelving systems. Retailers must consider the type of floor upon which the shelving will be installed.

**Impact Loading** Impact during the loading and unloading of merchandise can create an adverse loading situation and may result in damage to or failure of the Madix shelving. Do not walk or climb on Madix shelving.

**Overtipping** Overloading the top portion of the shelving, non-uniform loading, out-of-plumb installation, and impact can cause shelving to overturn. Improperly installed Madix shelving with offset loads can cause store fixtures to collapse. Carefully follow Madix's installation instructions in order to prevent shelving from overturning.

**Additional Shelving Safety Pointers** Product loading instructions are included with each Madix order. Retailers must make merchandisers aware of the product's load limitations and the dangers of overloading the shelving. Remove any merchandise or overstock before attempting to move Madix shelving. Periodically inspect your Madix shelving for damaged or loose parts. Make sure that shelves and accessories are properly seated in the slotting or perforations. Make sure that shelves and accessories are not overloaded. As merchandising changes, beware of creating offset loads on shelving runs that are not properly leveled. Look for leveling warning signs such as increased gaps between shelves or accessories that may indicate that the shelving runs need re-leveling. Damage to Madix shelving is dangerous. In some cases, the shelving should be unloaded immediately and repaired or replaced before returning to service. Re-level fixtures that you have bumped or moved. Incorporate safety into your merchandising strategy. When possible, merchandise the heavier products on the lower shelves. If the merchandise will not fit on the Madix shelves and there is a replenishment cycle, make sure that the cycle is a safe one. Make sure that merchandise and overstock are properly stacked and maintained so that items will not fall into the aisles. Assure that customers who handle merchandise or overstock will not push product from one side of the Madix fixture to the other side where people could be injured from falling merchandise. Safely secure overstock that is placed on Madix shelves overhead. Measure the difficulty that your employees have in retrieving overstock, and consider whether employees or customers could be injured if the product happens to fall from the shelving units. Teach employees and inform customers that Madix shelves should never be used as ladders to reach higher shelves. Ladders should be clearly marked for employees use only and should not be left unattended, or customers will try to remove stock on higher shelves by themselves. Notify customers to ask for assistance when they need product that is out of their reach.

**POSSESSION OF THIS CATALOG IS NOT AUTHORIZATION TO SELL MADIX PRODUCTS!  
ALL FACTORY QUOTES ARE GOOD FOR 30 DAYS ONLY.**

## Finish Policy for Metal Products

**Standard Colors, Returnable– Code A** Madix standard returnable colors for display shelving are Sahara, Blue Gray, Oyster, Snow White, and Satin Black. Madix standard returnable colors for wire products only are Powder Chrome and Silver Vein. All catalog items are priced in standard color.

**No Charge Colors (Non-Returnable)– Code B** Madix non-returnable colors offered at the standard price are Chocolate, Dove Gray, Dover White, Fashion Gray, Skyline Gray and Tru Gray. All catalog items are priced in standard color.

**Optional Colors-Level I Finishes (Non-Returnable)– Code B** Madix offers optional colors, also known as Grade I Finishes, at additional charge: Bright Orange, Hollyberry, Hunter Green, Mandarin, Neon Blue, Spectrum Blue, Spectrum Green, Spectrum Red and Valencia. Products painted with these colors are non-returnable.

**Metal Components:** \$350.00 line charge plus published per-piece charge. **Metal Back panels:** \$350.00 line charge plus published per-piece charge.

**Special Colors– Code C** Use line change charge plus per piece charge supplied by customer service. Special colors are non-returnable.

### Pricing For Levels II To IV:

**Level II:** 1.6 x Optional Color Upcharge. **Example:** Optional upcharge for SUS is \$1.50; upcharge with Level II finish will be \$2.40.

**Level III:** 2.8 x Optional Color Upcharge. **Example:** Optional upcharge for SUS is \$1.50; upcharge with Level III finish will be \$4.20.

**Level IV:** 3.8 x Optional Color Upcharge. **Example:** Optional upcharge for SUS is \$1.50; upcharge with Level IV finish will be \$5.70.

**Metal Components:** \$500.00 line charge plus published per-piece charge. **Back panels:** \$350.00 line charge plus published per-piece charge.

## Maintenance for Metal Products

**Baked Enamel and Powder Coated Finishes** All metal parts are finished with a specially formulated high solids or powder which are electrostatically bonded in a unique multi-stage process to insure the highest quality finish. Aerosol cans of touch-up paint are available in Madix's standard and optional colors. FAA regulations prohibit the shipment of this product by air or in export containers by air or ocean to countries outside the United States.

**Product Maintenance** When cleaning Madix shelving, use a non-abrasive mild detergent and warm water, followed by thorough drying. Using a soft white cotton cloth is strongly recommended. Cleaning products containing abrasives, bleach, or strong solvents will result in damage to the finish, especially when used on colors containing leafing aluminum pigment, such as powder chrome or vein-type finishes.

## Finish Policy for Wood Products

**High Pressure Laminate** The terms "laminates" or "HPL" are commonly applied to this material which consists of multiple layers of paper infused with phenolic resin and topped by a finish paper coated with clear melamine resin, all totally bonded under high pressure and heat. The finished sheet has extremely high wear and impact resistance.

**Customer Specified High Pressure Laminate** Madix coding is based on Wilsonart availability. Laminates other than Wilsonart may require additional lead time.

- Customer specified laminates add \$100.00 per pattern, per order
- Additional charge will apply based on the laminate grade that is chosen

Laminates that are not from a laminate manufacturer's standard samples (metallics, heavy textures, wet looks, core edge, special prints) will require a special quote. Contact Customer Service for specific pricing on laminates not listed above.

**Thermofused Panels** Thermofused panels are ideal for non-wear surfaces and have substantial impact and wear characteristics compared to melamine panels previously available. The product is produced using hot press laminating polyester or melamine resin impregnated self-bonding paper to wood substrate. Performance specifications are available from the American Laminations Association. Madix does not recommend the use of Thermofused panels on horizontal or other wear surfaces.

**Printed Mirror Hardboard** Printed materials are primarily used for back panels, but appear as various other products. These materials are carefully cross matched to the corresponding laminates and Thermofused. Mylar mirror hardboard is used in the same applications and is also

available in pegboard and grooved pegboard. **Finish Policy for Back Panels**

**Standard Colors, Returnable– Code A** Madix standard returnable colors for display shelving back panels are Sahara, Oyster, and Snow White.

**Optional Colors-Level I Finishes (Non-Returnable)– Code B** Madix non-returnable back panel colors offered at the optional price are Chocolate, Dove Gray, Dover White, Fashion Gray, Satin Black, Skyline Gray, Blue Gray and Tru Gray. Set-up charge of \$350.00 applies.

**Optional Colors-Level II Finishes (Non-Brilliant)– Code B** Madix offers optional back panel colors also known as non-brilliant finishes at an additional charge. These colors include custom grays, off whites, tans, and beiges not listed in Madix's Finishes brochure. Products painted with these colors are non-returnable. Set-up charge of \$350.00 applies.

**Optional Colors-Level III Finishes (Brilliant)– Code C** Brilliant back panel finishes include Hunter Green, Neon Blue, Spectrum Blue, and Spectrum Green. Set-up charge of \$350.00 applies.

**Optional Colors-Level IV Finishes (Reds and Yellows)– Code C** Use line change charge plus per piece charge supplied by customer service. Special colors are non-returnable. Set-up charge of \$350.00 applies.

### Pricing For Levels II To IV

**Level II** 1.2 x the difference between the Hardboard/Pegboard Optional Color pricing and the Hardboard/Pegboard Sahara pricing. **Example:** Optional upcharge for a BH-342 with a Level II finish would be calculated as follows: \$13.85 - \$12.45 = \$1.40 x 1.2 = \$1.68. The color upcharge for a BH-342 with a Level II finish is \$1.68. This upcharge amount will be added to the Optional Color price of a BH-342. The new price of a BH-342 using a Level II finish is \$15.53 (\$13.85 + \$1.68 = \$15.53).

**Level III** 1.4 x the difference between the Hardboard/Pegboard Optional Color pricing and the Hardboard/Pegboard Sahara pricing. **Example:** Optional upcharge for a BH-342 with a Level III finish would be calculated as follows: \$13.85 - \$12.45 = \$1.40 x 1.4 = \$1.96. The new color upcharge for a BH-342 with a Level III finish is \$1.96. This upcharge amount will be added to the Optional Color price of a BH-342. The new price of a BH-342 using a Level III finish is \$15.81 (\$13.85 + \$1.96 = \$15.81).

**Level IV** 1.8 x the difference between the Hardboard/Pegboard Optional Color pricing and the Hardboard/Pegboard Sahara pricing. **Example:** Optional upcharge for a BH-342 with a Level IV finish would be calculated as follows: \$13.85 - \$12.45 = \$1.40 x 1.8 = \$2.52. The color upcharge for a BH-342 with a Level IV finish is \$2.52. This upcharge amount will be added to the Optional Color price of a BH-342. The new price of a BH-342 using a Level IV finish is \$16.37 (\$13.85 + \$2.52 = \$16.37).

**NOTE!** See Finishes Brochure for color samples.



Part Name	Part Number	Page Number
<b>S</b>		
Seismic Floor Anchor.....	SFA-RD-1.....	10
Seismic Floor Bolt.....	SFA-EB50.....	10
<b>T</b>		
Tube Line Back Single to Double Track.....	TLBTSD7-(NH)-(COLOR).....	10
Tube Line Bottom Stretcher, Double Back.....	TLBS2(NW).....	10
Tube Line Counter Base End One Piece End Trim.....	TLCBOP(LS)(RS)7.....	9
Tube Line Counter Extension Upright Single Track, End & Int.....	TLCE1(OPT)(NH).....	13
Tube Line Counter Extension without Panel Retainers.....	TLCE(NH).....	13
Tube Line Counter Kickplate.....	TLCK(NW)7.....	9
Tube Line Counter Kickplate Open Frame.....	TLCKOF(NW).....	9
Tube Line Counter Kickplate Rear.....	TLCKR(NW)7.....	9
Tube Line Counter Uprights-Single Back End & Int., No Levelers.....	TLCUNL1(OPT)(NH)(LS)(RS)7.....	8
Tube Line Feature End Deck.....	TLFE(NH).....	12
Tube Line Feature End Deck Kickplate.....	TLFEDK(LS)(RS)7.....	12
Tube Line Feature End Deck Shelf with Double Perforation.....	TLFEDSD(ND)(LS)(RS).....	12
Tube Line Feature End Frame.....	TLFFCF(OPT1)(NW)(NH)7(OPT2).....	13
Tube Line Feature End Side Rail Base.....	TLFEDR(ND)7(OPT).....	12
Tube Line Half Counter Base End Trim One Piece.....	TLHBOP(ND)7(OPT).....	9
Tube Line Half Counter Uprights-Single Back End, No Levelers.....	TLHUNL1(OPT)(NH)(ND)7.....	8
Tube Line Metal Shelf.....	TLMS(OPT)(NW)(ND)-(TAG)(COLOR).....	12
Tube Line Side Deck.....	TLSD(NW)(ND).....	11
Tube Line Single Back.....	TLB1(NW)(NH)7(TYPE)(COLOR)X2.....	11
Tube Line Top Cap, Single Back.....	TLTC1(NW).....	10
Tube Line Triple Back.....	TLB3(NW)(NH)7(TYPE)-(COLOR)X2.....	11
Tube Line Upright Attachment.....	TLWUAK(OPT).....	13
Tube Line Upright Cap with Slot.....	TLUCS.....	10
Tube Line, Double Top Cap.....	TLTC2(OPT)(NW).....	10





**Innovation on Display Since 1956**



[www.madixinc.com](http://www.madixinc.com)

**Texas** 500 Airport Road, Terrell, TX 75160 | 1010 S. Bolton, Jacksonville, TX 75766  
**Alabama** 20984 Alabama Hwy. 9, Goodwater, AL 35072 | 500 Madix Drive, Eclectic, AL 36024