

T - RACK FIXTURE SYSTEM

INSTALLATION INSTRUCTIONS

1

The T-rack system is available in two versions: open back and closed back.

1

While an assistant holds uprights, inset pins of 1x2 tie bar into keyhole slots at bottom of upright. Make sure offset side of plate on tie bar ends face **upwards**. Tap ends of tie bar with a rubber mallet to seat pins into keyholes.

2

If installing closed back system, slide back panel into channels of uprights and seat back panel into channel of lower tie bar. Install upper tie bar into keyhole slots at top of uprights, making sure that offset side of plate on tie bar ends face **downwards**. If closed back system, make certain back panel fits into channel of upper tie bar.

Seat pins of tie bar into keyholes with rubber mallet.

3

If using optional diagonal stabilizer in open back system, install stabilizer with lower offset plate resting on lower tie bar using provided self tapping screws. Also, see ASY1-064

4

To install end frame, lower end frame so that tab at top of frame and clips at bottom of frame engage upright consecutively. Leveling legs of end frame should be adjusted to hold weight of end frame on floor.

5

Insert blades of upright extension into the top of upright and tap with rubber mallet to set extension in place.

6

Adjust all levelers.

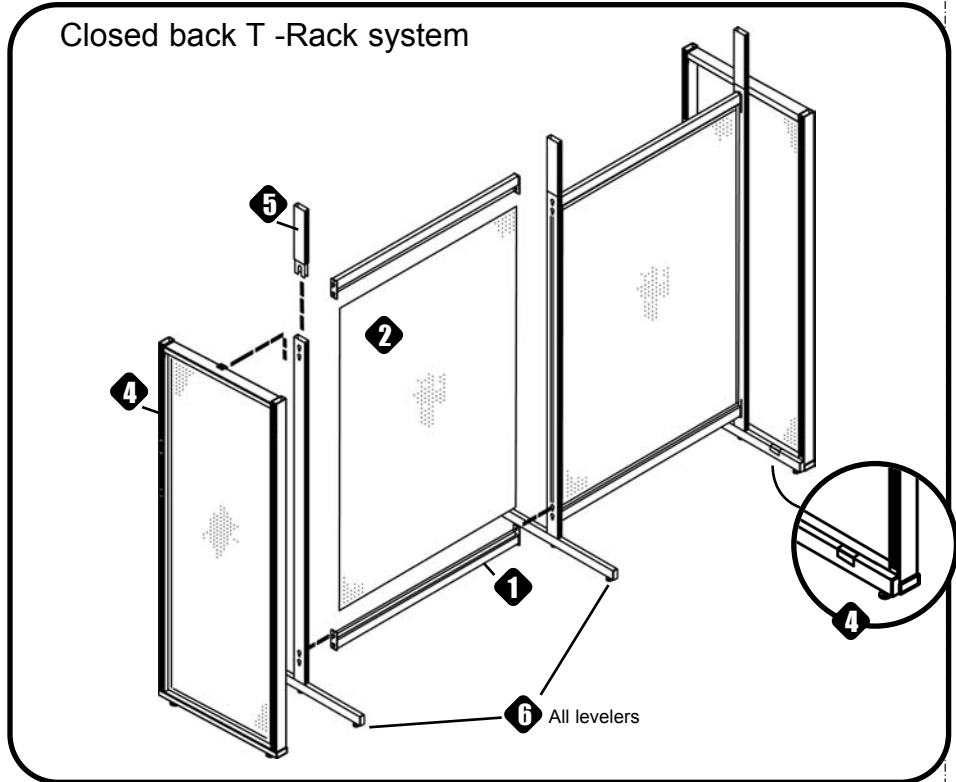
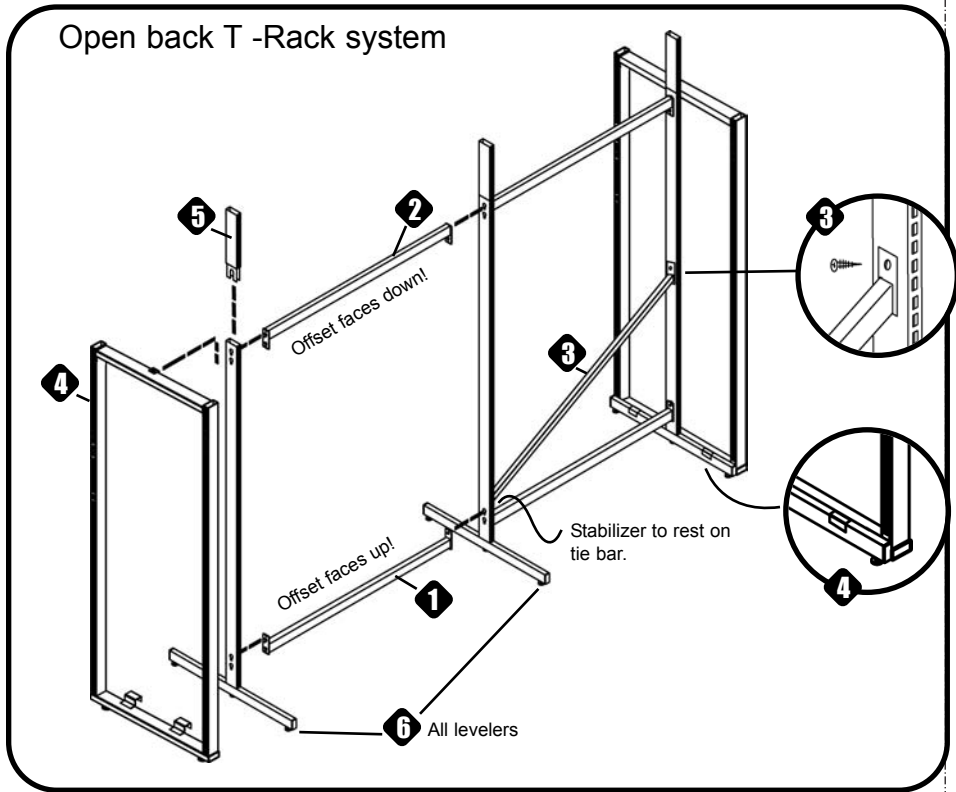

THERE IS A 50% REDUCTION IN LOAD CAPACITY IF MAXI-LINE COMPONENTS ARE USED WITH T-RACK!

INSTALLATION COMPLETE



P.O. BOX 729 / TERRELL, TEXAS 75160 / 972.563.5744 / 800.776.2349
 P.O. BOX 177 / GOODWATER, ALABAMA 35072 / 256.839.6354 / 800.633.6282

REV B

REV#	ECN#	REVISION	BY	DATE	REV#	ECN#	REVISION	BY	DATE
A		update / reflect product change	AJB	12/7/01					
B	AL002145	add warn on maxiline	AJB	10/7/02					