

END CAP MOUNTING SYSTEM ASY 135 A

INSTALLATION INSTRUCTIONS

The End Cap consists of the following components...

- | | |
|----------------------------|-----------------------|
| 2 Basic 96" Uprights | 1 Hardboard |
| | 1 Pegboard |
| 2 Metal Upright Caps | Lower Back Panel |
| 2 Metal Upright End Covers | 1 Hardboard |
| | 1 Pegboard |
| | Upper Back Panel |
| Spanners: | |
| 1 Lower | 2 Center |
| 1 Splicer | 1 Top |
| | 1 Open Back Stiffener |
| | 1 Rear Kickplate |

1

After assembly of the End Cap(s), the Basic Upright levelers are to be extended a total of 3/4" from the bottom of the leveler bracket to the bottom of the leveler head. (This is an important step to center the slot at 12 1/2" and 84 1/2" with the center of the Mounting Tube.) Install the Upright End Covers and the Upright Top Caps. (When 2 End Caps are used together and are installed immediately next to each other, the Upright End Covers are omitted on the interior Uprights.)

2

The Mounting Tubes are to be installed with their centerlines at 12 1/2" and 84 1/2" above the floor. 1/4-20 Bolts are used for installation throughout. When utilizing Mounting Clamps, the Bolts are to be installed in the slots as close to the Tube as possible and through the existing square holes in the Uprights. The bolt heads are to be on the end cap side and the nuts on the inside of the frame. 1/4 flat washers are used under the bolt heads and under the nuts. The Mounting Tubes are to be attached to all vertical Uprights except the Basic Uprights of the Hypermaxi Units.

3

It may be necessary to loosely install the Mounting Tubes to the Uprights and then loosely install the End Caps to the Mounting Tubes. If so, go back and center the Mounting Tubes as close as possible. Then tighten the Mounting Tube Mounting Clamp Nuts to complete the installation.

In some circumstances, it may be necessary to use an open end or box end wrench on the Nuts and the socket on the Bolt head to tighten them.

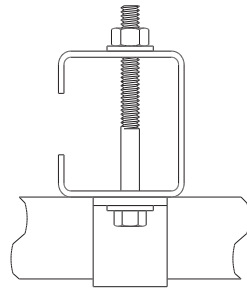

Mounting Type **1**

- 1 - Clamp
- 4 - 1/4 Flat Washers
- 2 - 1/4 - 20 Hex Nuts

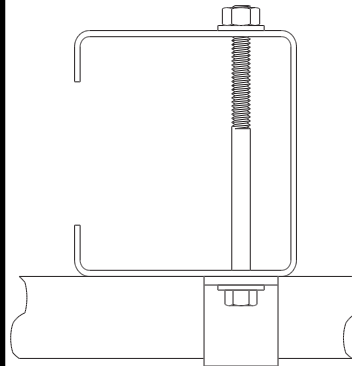

Mounting Type **2**

- 1 - Clamp
- 2 - 1/4-20x3 1/2 Hex Head Bolts
- 4 - 1/4 Flat Washers
- 2 - 1/4 - 20 Hex Nuts

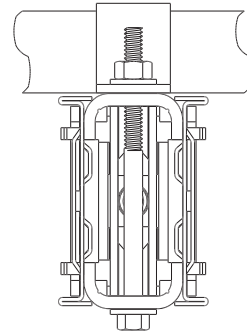

Mounting Type **3**

- 1 - Clamp
- 2 - 1/4-20x3 1/2 Hex Head Bolts
- 4 - 1/4 Flat Washers
- 2 - 1/4 - 20 Hex Nuts

Notes...

In some conditions the "Tube-to-Frame" Mounting Clamp and the "Tube-to-End Cap" Mounting Clamp may be immediately adjacent to each other.

Views above are approximately 40% size.

Refer to any attached page(s) for specific End Cap applications, where these mounting types are shown. The illustrations may or may not be pictorially exact.



P.O. BOX 729 / TERRELL, TEXAS 75160 / 972.563.5744 / 800.776.2349
 P.O. BOX 177 / GOODWATER, ALABAMA 35072 / 205.839.6354 / 800.633.6282



REV#	ECN#	REVISION	BY	DATE	REV#	ECN#	REVISION	BY	DATE
A		REDESIGNED	CCM	11/16/89					
B		REDRAWN TO NEW FORMAT	CCM	6/22/93					
C	5115	REVISE LAYOUT	ACM	6/18/00					

END CAP MOUNTING SYSTEM

ASY 135 B

INSTALLATION INSTRUCTIONS

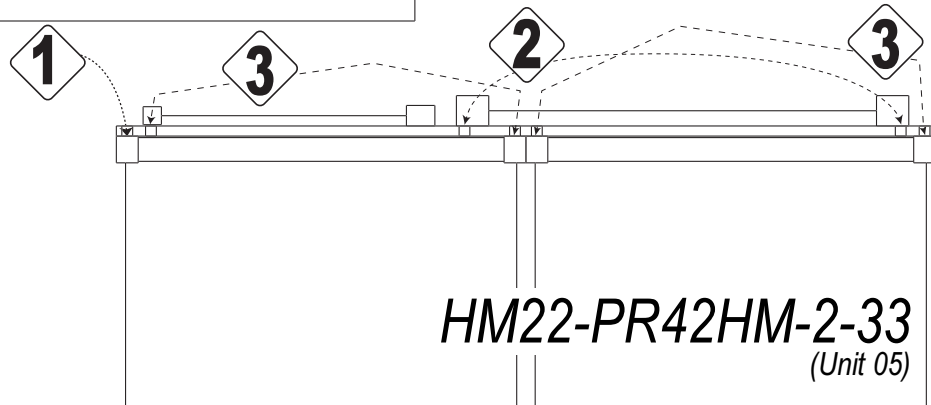
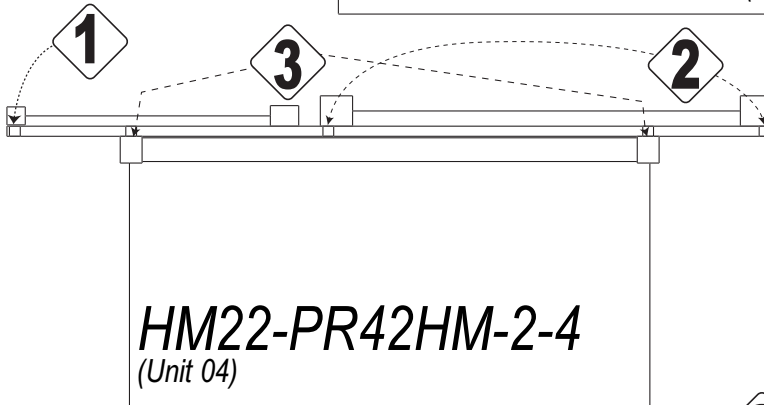
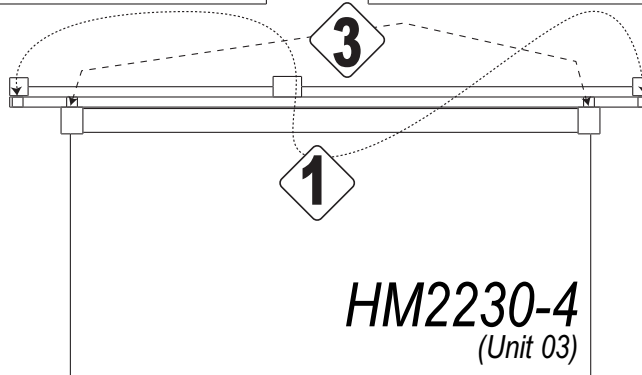
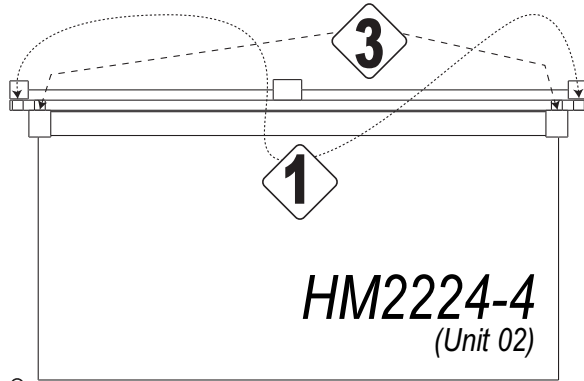
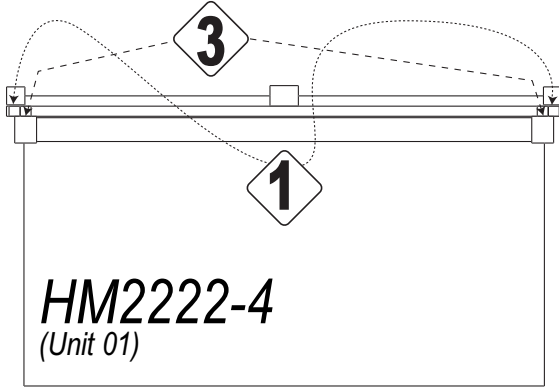

P.O. BOX 729 / TERRELL, TEXAS 75160 / 972.563.5744 / 800.776.2349
 P.O. BOX 177 / GOODWATER, ALABAMA 35072 / 205.839.6354 / 800.633.6282



REV#	ECN#	REVISION	BY	DATE	REV#	ECN#	REVISION	BY	DATE
A		REDESIGNED	CCM	11/16/89					
B		REDRAWN TO NEW FORMAT	CCM	6/22/93					
C	5115	REVISE LAYOUT	ACM	6/19/00					

END CAP MOUNTING SYSTEM

PAGE 1 OF 1
ASY 135 C

INSTALLATION INSTRUCTIONS

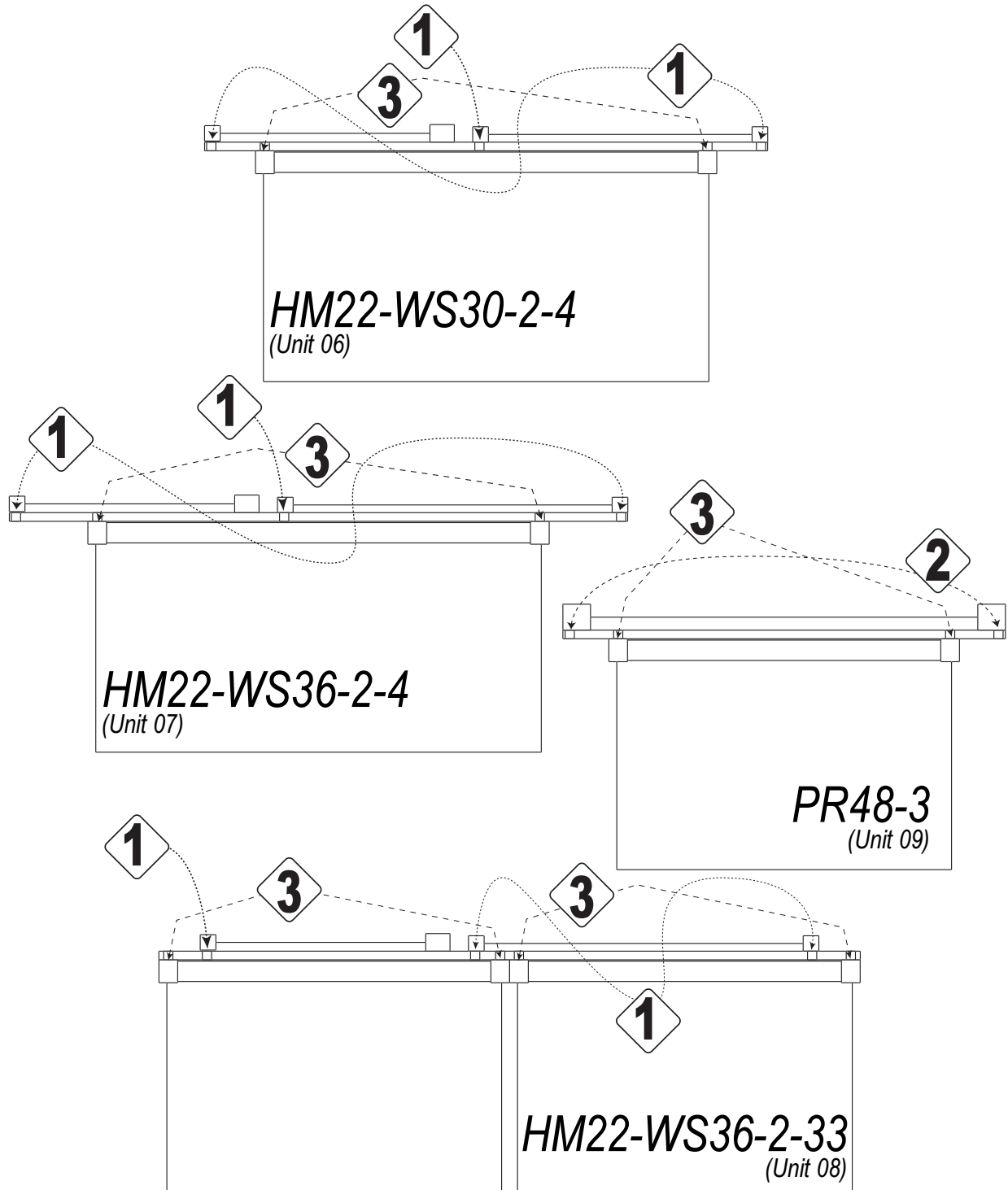

P.O. BOX 729 / TERRELL, TEXAS 75160 / 972.563.5744 / 800.776.2349
 P.O. BOX 177 / GOODWATER, ALABAMA 35072 / 205.839.6354 / 800.633.6282

REV
C

REV#	ECN#	REVISION	BY	DATE	REV#	ECN#	REVISION	BY	DATE
A		REDESIGNED	CCM	11/16/89					
B		REDRAWN TO NEW FORMAT	CCM	6/22/93					
C	5115	REVISE LAYOUT	ACM	6/18/00					

END CAP MOUNTING SYSTEM

ASY 135 D

INSTALLATION INSTRUCTIONS

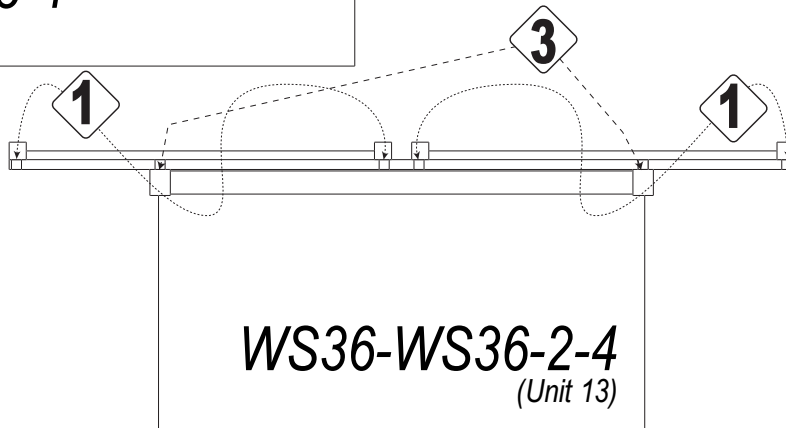
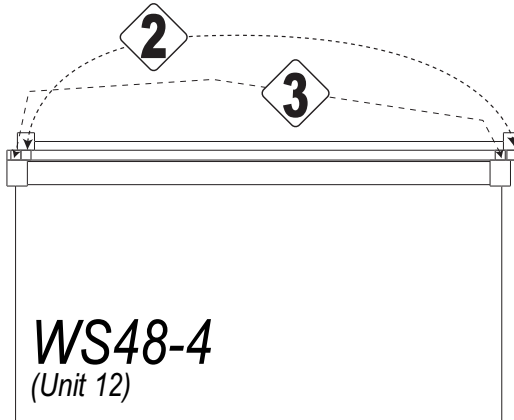
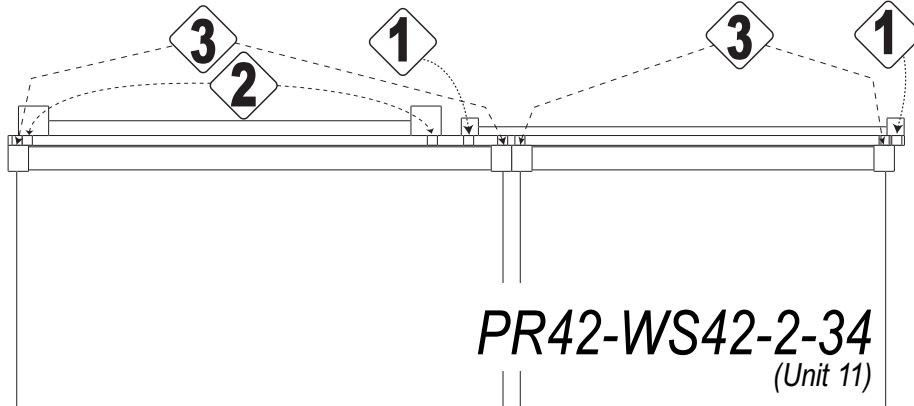
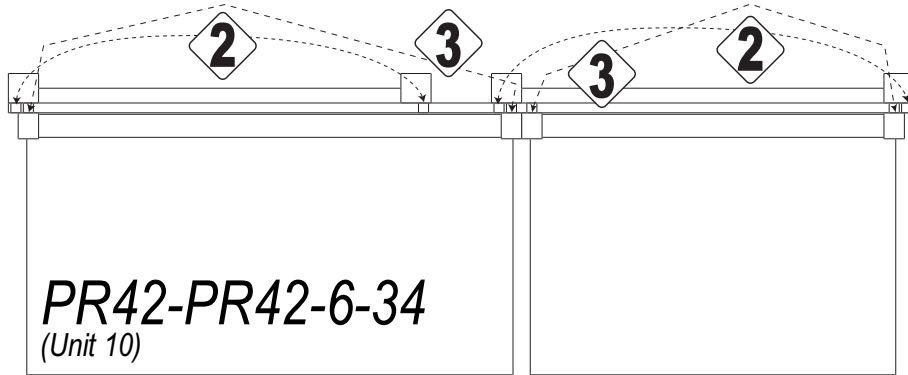

STORE FIXTURES

P.O. BOX 729 / TERRELL, TEXAS 75160 / 972.563.5744 / 800.776.2349

P.O. BOX 177 / GOODWATER, ALABAMA 35072 / 205.839.6354 / 800.633.6282

REV C

REV#	ECN#	REVISION	BY	DATE	REV#	ECN#	REVISION	BY	DATE
A		REDESIGNED	CCM	11/16/93					
B		REDRAWN TO NEW FORMAT	CCM	6/22/93					
C	5115	REVISE LAYOUT	ACM	6/19/00					

END CAP MOUNTING SYSTEM

ASY 135 E

INSTALLATION INSTRUCTIONS

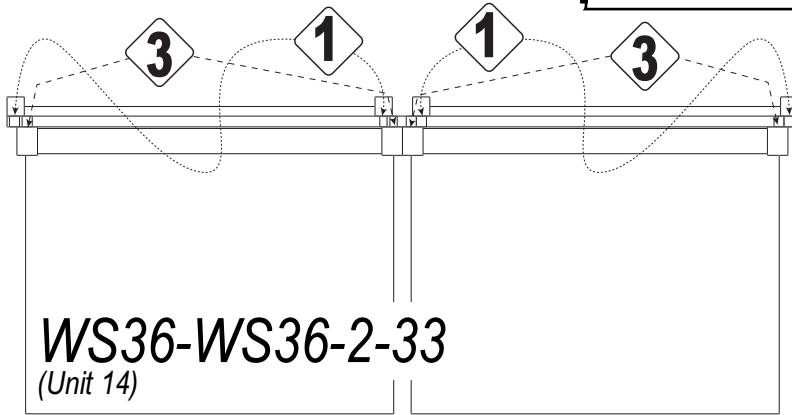

WS36-WS36-2-33
(Unit 14)

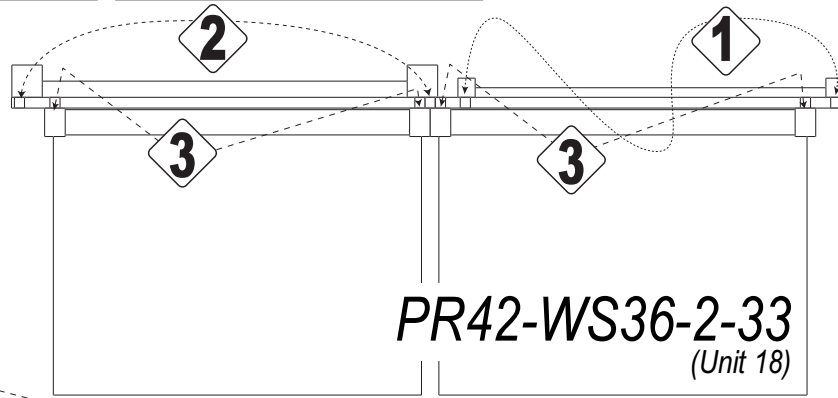

PR42-WS36-2-33
(Unit 18)

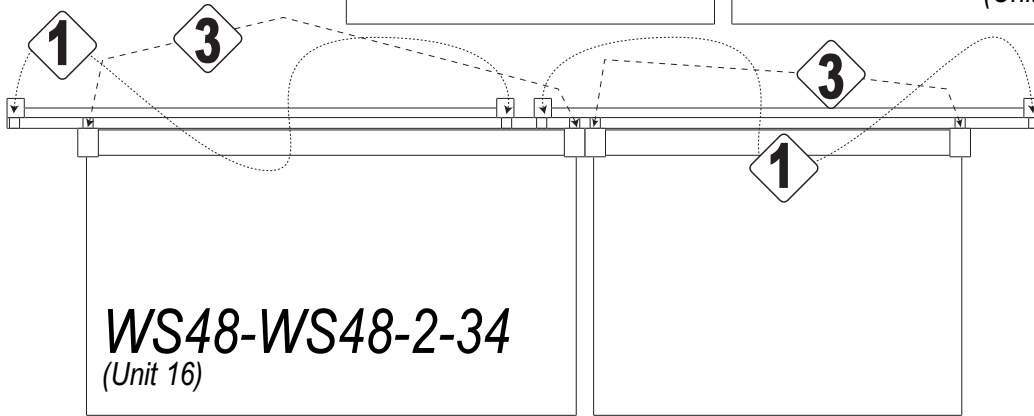

WS48-WS48-2-34
(Unit 16)

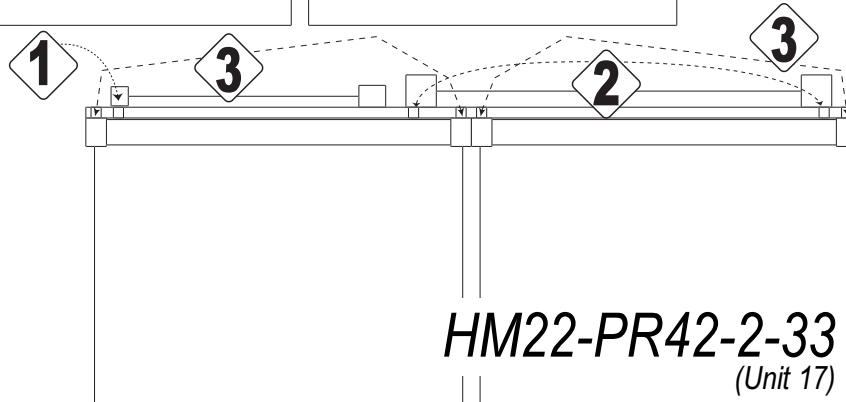

HM22-PR42-2-33
(Unit 17)



P.O. BOX 729 / TERRELL, TEXAS 75160 / 972.563.5744 / 800.776.2349
P.O. BOX 177 / GOODWATER, ALABAMA 35072 / 205.839.6354 / 800.633.6282

REV
C

REV#	ECN#	REVISION	BY	DATE	REV#	ECN#	REVISION	BY	DATE
A		REDESIGNED	CCM	11/16/89					
B		REDRAWN TO NEW FORMAT	CCM	6/22/93					
C	5115	REVISE LAYOUT	ACM	6/19/00					

END CAP MOUNTING SYSTEM

ASY 135 F

INSTALLATION INSTRUCTIONS

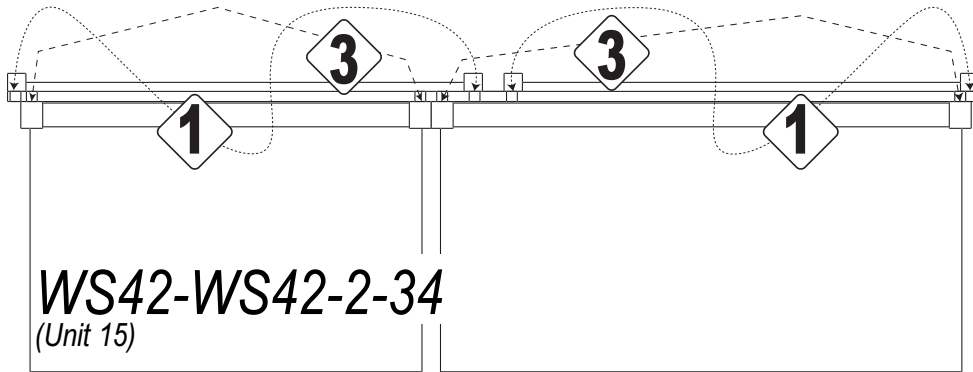

WS42-WS42-2-34
(Unit 15)

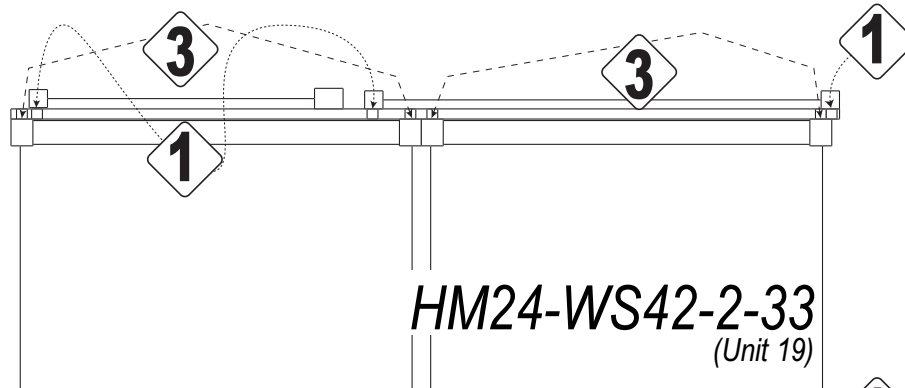

HM24-WS42-2-33
(Unit 19)

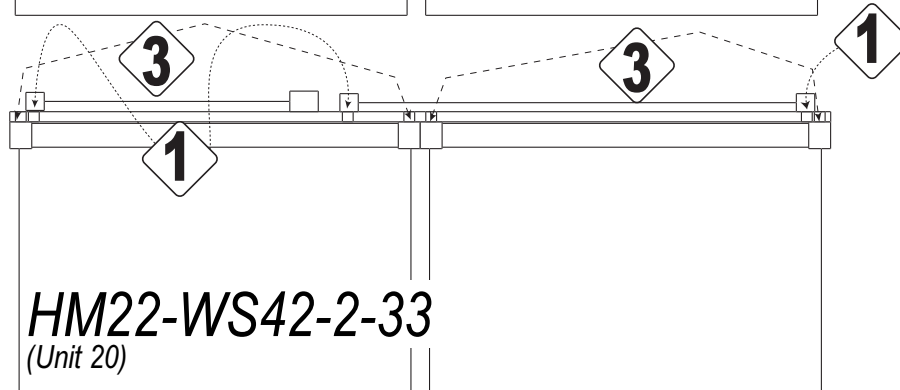

HM22-WS42-2-33
(Unit 20)

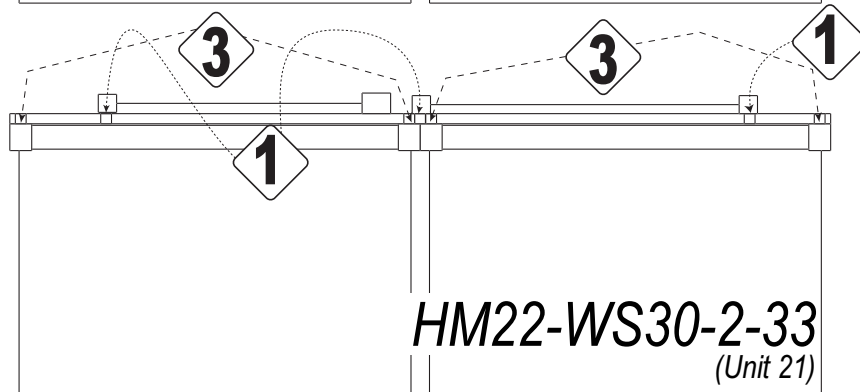

HM22-WS30-2-33
(Unit 21)



P.O. BOX 729 / TERRELL, TEXAS 75160 / 972.563.5744 / 800.776.2349
P.O. BOX 177 / GOODWATER, ALABAMA 35072 / 205.839.6354 / 800.633.6282

REV D

REV#	ECN#	REVISION	BY	DATE	REV#	ECN#	REVISION	BY	DATE
A		ADDED UNIT 20 & 21	CCM	7/10/89	D		REVISE LAYOUT	ACM	6/19/00
B		REDESIGNED	CCM	11/16/89					
C		REDRAWN TO NEW FORMAT	CCM	6/22/93					

END CAP MOUNTING SYSTEM

ASY 135 G

INSTALLATION INSTRUCTIONS

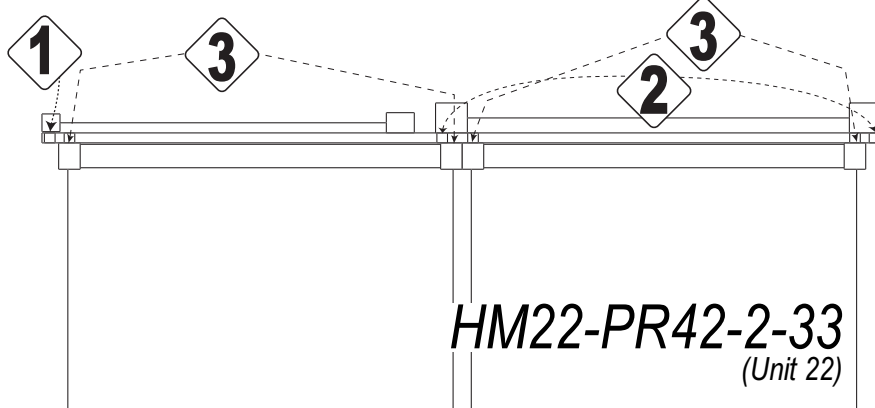

HM22-PR42-2-33
(Unit 22)

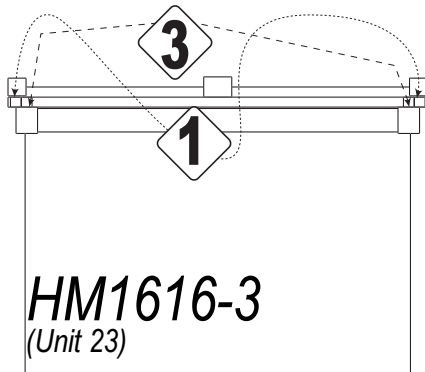

HM1616-3
(Unit 23)

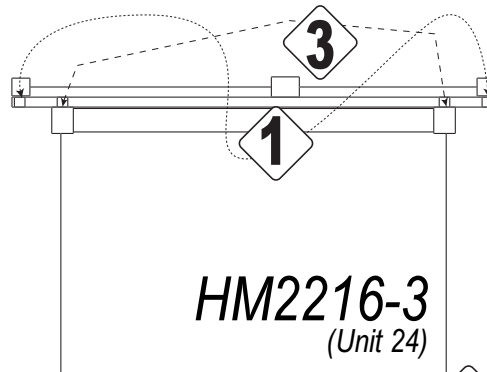

HM2216-3
(Unit 24)

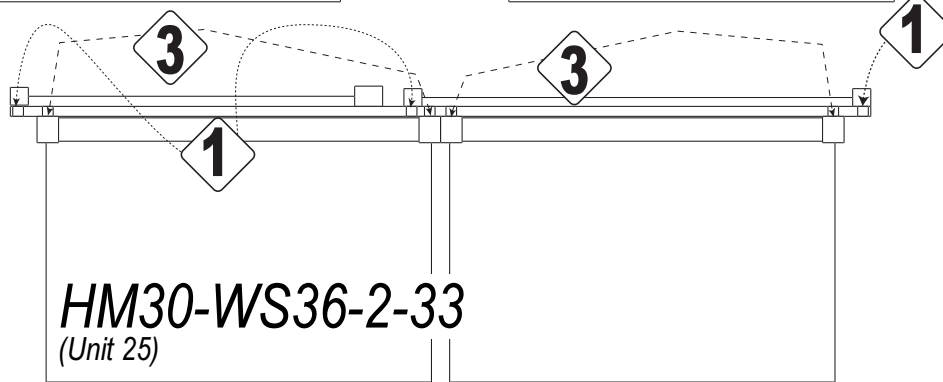

HM30-WS36-2-33
(Unit 25)

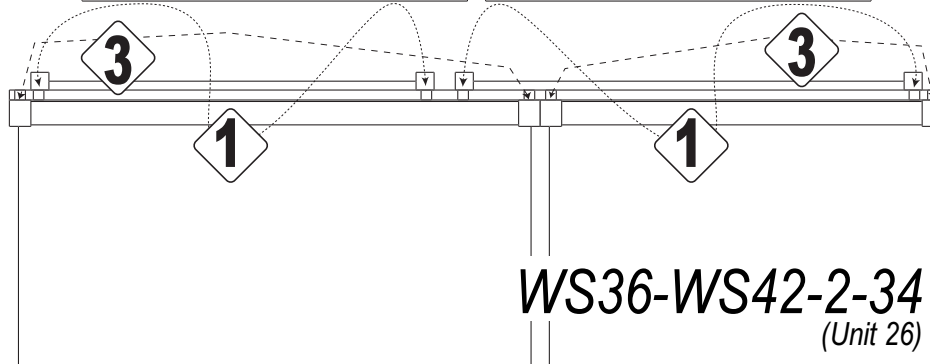

WS36-WS42-2-34
(Unit 26)



P.O. BOX 729 / TERRELL, TEXAS 75160 / 972.563.5744 / 800.776.2349
 P.O. BOX 177 / GOODWATER, ALABAMA 35072 / 205.839.6354 / 800.633.6282



REV#	ECN#	REVISION	BY	DATE	REV#	ECN#	REVISION	BY	DATE
A	RFQ4204	ADDED UNITS 23 & 24	CCM	7/13/90	D		REDRAWN TO NEW FORMAT	CCM	6/22/93
B		ADDED UNIT 25	CCM	8/20/90	E	5115	REVISE LAYOUT	ACM	6/19/00
C		ADDED UNIT 26	CCM	3/30/91					

END CAP MOUNTING SYSTEM

ASY 135 H

INSTALLATION INSTRUCTIONS

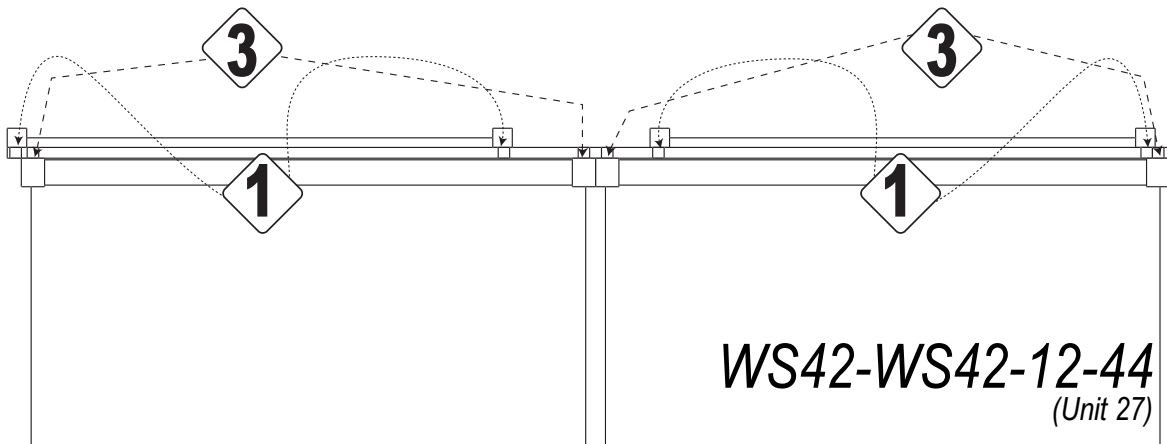

WS42-WS42-12-44
(Unit 27)

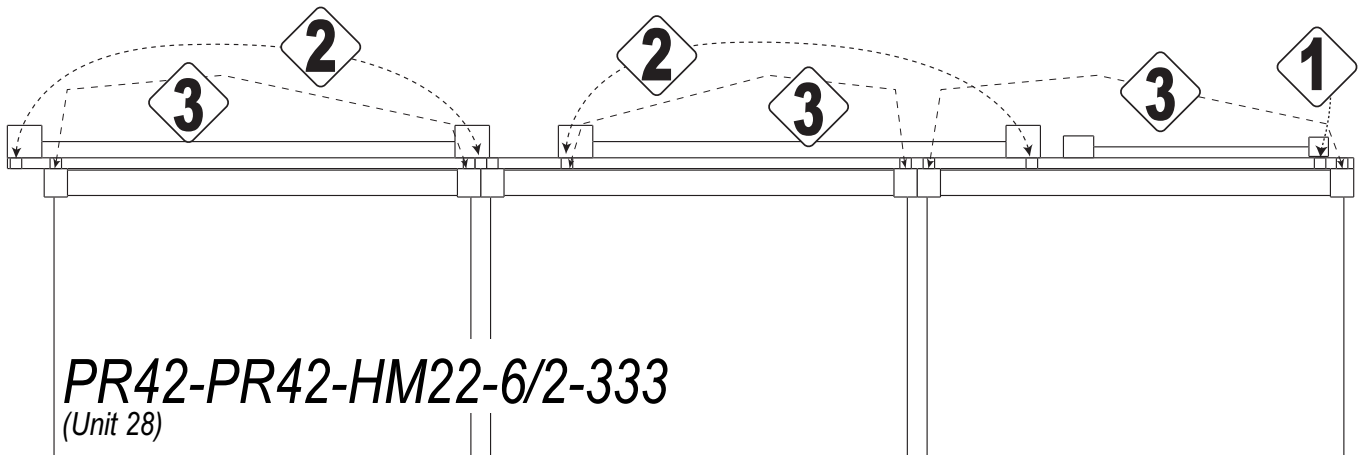

PR42-PR42-HM22-6/2-333
(Unit 28)



P.O. BOX 729 / TERRELL, TEXAS 75160 / 972.563.5744 / 800.776.2349

STORE FIXTURES

P.O. BOX 177 / GOODWATER, ALABAMA 35072 / 205.839.6354 / 800.633.6282

REV
C

REV#	ECN#	REVISION	BY	DATE	REV#	ECN#	REVISION	BY	DATE
A		REDRAWN TO NEW FORMAT	CCM	6/22/93					
B		REVISED CALL OUTS	CCM	1/28/94					
C	5115	REVISE LAYOUT	ACM	06/19/00					

END CAP MOUNTING SYSTEM

INSTALLATION INSTRUCTIONS

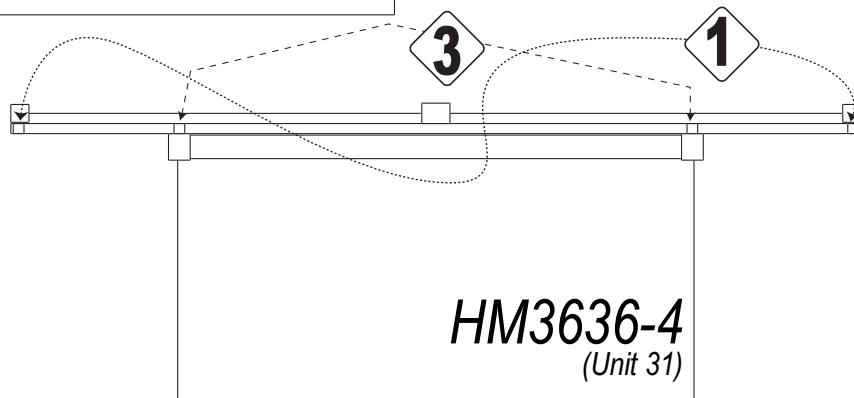
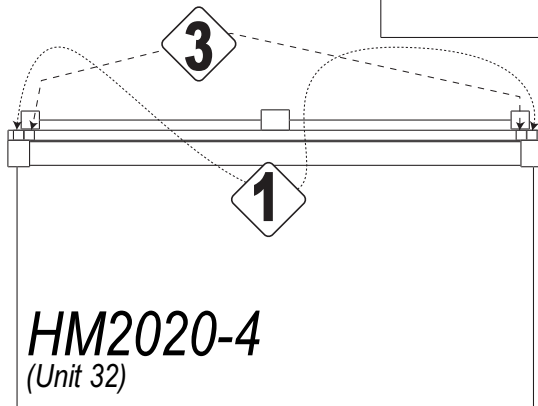
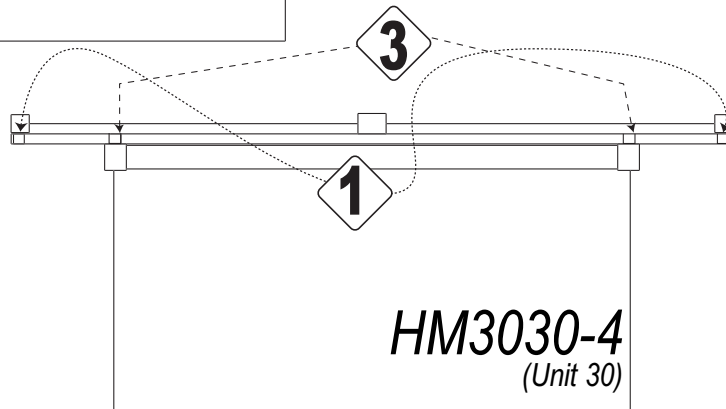
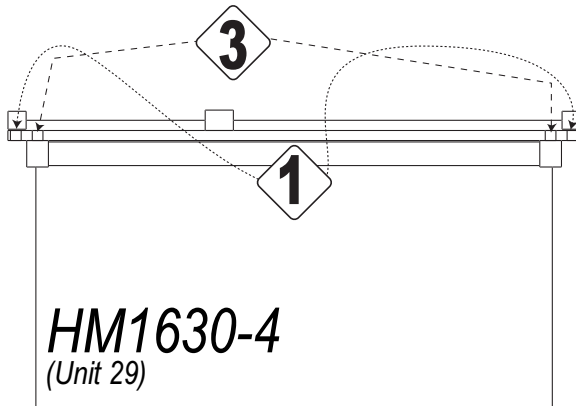

P.O. BOX 729 / TERRELL, TEXAS 75160 / 972.563.5744 / 800.776.2349
P.O. BOX 177 / GOODWATER, ALABAMA 35072 / 205.839.6354 / 800.633.6282

REV D

REV#	ECN#	REVISION	BY	DATE	REV#	ECN#	REVISION	BY	DATE
A		ADDED UNIT 30	CCM	5/4/92	D	5115	REVISE LAYOUT	ACM	6/19/00
B		ADDED UNIT 31, CHANGED TO NEW FORMAT	CCM	6/22/93					
C		ADDED UNIT 32	CCM	1/28/94					