

# TELESCOPING UPRIGHT

PAGE 1 OF 2

## ASY 027

ASSEMBLY INSTRUCTIONS

NOTE: Telescoping Uprights are for use in 48", 54", 60", and 72" high sections only!  
Contact your Madix representative on sections higher than 72".

**IMPORTANT!**

1 additional center spanner must be installed in each section.

PER SECTION:

- 1 TELESCOPING UPRIGHT
- 1 TELESCOPING UPRIGHT STIFFNER
- 1 CENTER SPANNER
- 1 TELESCOPING UPRIGHT RETAINER PIN

**1**

Place 1 additional center spanner (from telescoping upright kit) in the parts layout of each section in the run. ALL SECTION LAYOUTS SHOULD HAVE 2 TOP/LOWER SPANNERS AND 2 CENTER SPANNERS.

**2**

Place one top/lower spanner on a firm surface. using a screwdriver and hammer as shown, punch down each corner of center knockout and remove. THIS SPANNER IS FOR TOP OF SECTION.

**3**

Install remaining top/lower spanner in bottom position and one center spanner at 36" above floor regardless of upright height. Install remaining spanner at 6" down from top of upright.

**4**

Complete installation of backs and top/lower spanner with knockout removed.

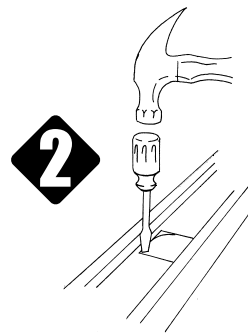

ADDITIONAL CENTER SPANNER FROM TELESCOPING UPRIGHT KIT

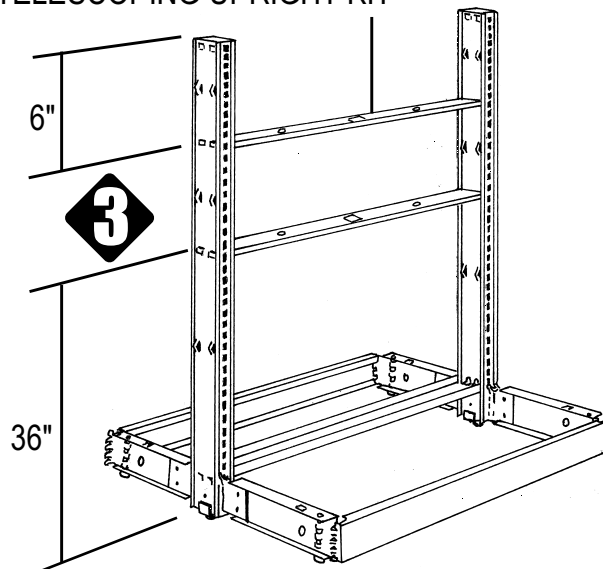

# TELESCOPING UPRIGHT

## ASY 027

### ASSEMBLY INSTRUCTIONS

**5**

Insert wooden Telescoping Upright Stiffener into hole in top/lower spanner and downward through both center spanners until it rests on the bottom spanner. If section is less than 60" in height, cut excess stiffener off flush with the top of the section.

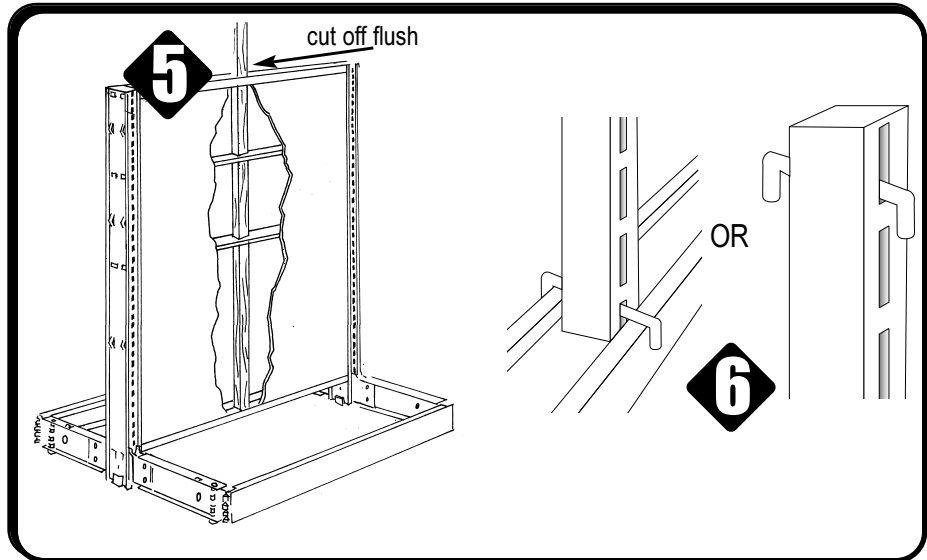

**6**

Insert Telescoping Upright over the Telescoping Upright Stiffener to the desired height and insert retainer pin completely through as shown.

OR

Insert retainer pin in the top slot and lower telescoping upright.

NOTE: TELESCOPING UPRIGHT SHOULD NOT PROJECT MORE THAN 18" ABOVE TOP OF SECTION... UPRIGHT ACCEPTS ONLY 2 TAB SHELVES (8"-18").

## ADD-ON INSTALLATION

**1**

Remove upright caps (if any) from all sections to receive Telescoping Uprights. Insert screwdriver into top slot of upright and pry up.

**2**

Remove top/lower spanners from all sections.

**4**

Proceed from Step #2 on first page.

**3**

Remove backs from one side of all sections.

ASSEMBLY COMPLETE



P.O. BOX 729 / TERRELL, TEXAS 75160 / 972.563.5744 / 800.776.2349  
 P.O. BOX 177 / GOODWATER, ALABAMA 35072 / 205.839.6354 / 800.633.6282



REV#	ECN#	REVISION	BY	DATE	REV#	ECN#	REVISION	BY	DATE
A	4859	CHNG PIN STYLE & PLCMT, REFORMAT ASY LAYOUT	ACM	2/9/00					
B	5135	CHANGE 30" TO 12", 20 TO 18" ON PG 2	ACM	6/26/00					
C	5337	CHANGE "12" ABOVE" TO "18" ABOVE" ON PG 2	ACM	9/20/00					