

COUNTERTOPS / WOOD SHELF BRACKETS

ASY 023

INSTALLATION INSTRUCTIONS

COUNTERTOP IDENTIFICATION & MOUNTING SITUATIONS

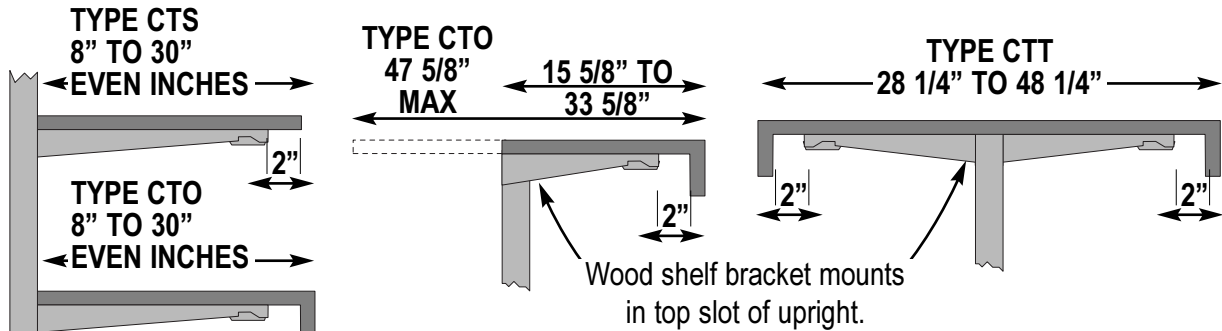

WOOD SHELF BRACKETS MUST BE 2" LESS THAN UNDERSIDE OF COUNTERTOP! SEE NEXT PAGE FOR EXCEPTIONS.

COUNTERTOP MARKINGS

Example: **CTO20-144 1/2"**

Type Width Length

These are ordered dimensions...
your actual dimensions
will vary slightly.

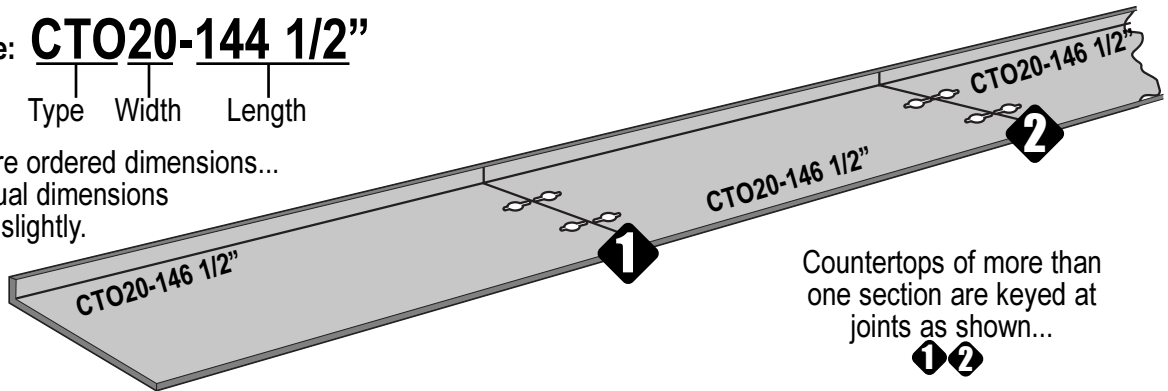

Countertops of more than one section are keyed at joints as shown...

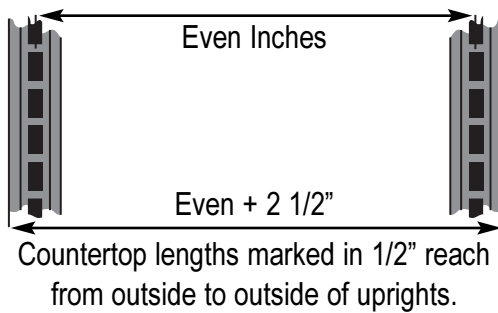

NOTE: Upright end covers **MUST** be installed **PRIOR** to countertops!

If end panels or canopy end panels are to be used, they also should be installed **PRIOR** to countertops.

LOWER SLIDING DOOR KITS (HARDBOARD) UNDER COUNTERTOPS

	WOOD SHELF BRACKET INSTALLS AT...	19" ABOVE BASE SHELF	25" ABOVE BASE SHELF	31" ABOVE BASE SHELF	37" ABOVE BASE SHELF
	LOWER KIT	SDK-H□18	SDK-H□24	SDK-H□30	SDK-H□36

NOTE: If drawer unit is to be used between countertop and door kit, add 6" to above dimensions.

COUNTERTOPS / WOOD SHELF BRACKETS

ASY 023

INSTALLATION INSTRUCTIONS

SIDE MOUNT LIGHT UNDER CTO OR CTT

Wood shelf bracket must be 6" less than underside of countertop...

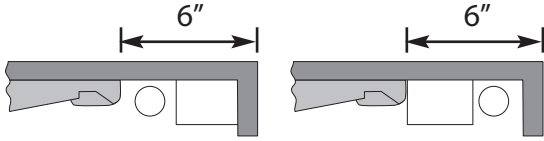

If sliding door kit is used, wood shelf bracket must be 8" less than underside of countertop.

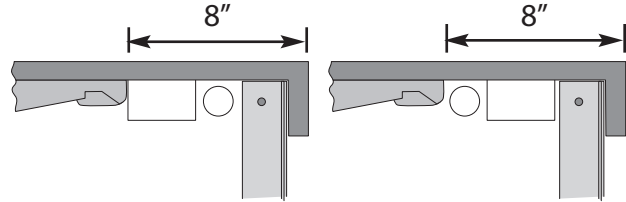

1 Install brackets in upright as shown. *NOTE: IF COUNTERTOP GOES OVER THE TOP OF THE UPRIGHT, REMOVE PLASTIC UPRIGHT CAPS: INSERT A SCREWDRIVER IN THE TOP SLOT OF THE UPRIGHT AND PRY UP.

2 Lay out countertop sections on floor as shown on other side of this sheet... underside up and front edge next to shelving run.

3 Insert tite joint connectors from hardware pack in routed cavities and tighten

4 Stand countertop on front edge... DO NOT RAISE IN FLAT POSITION!

5 Lift countertop straight up... rest rear edge on bracket nose as shown... raise front edge and slide back to uprights.

***** NO MORE THAN 16' OF ASSEMBLED COUNTERTOP SHOULD BE LIFTED IN TO POSITION! LONGER COUNTERTOPS MUST BE POSITIONED ON BRACKETS AS SUB-ASSEMBLIES NOT EXCEEDING 16' AND FINAL ASSEMBLY MADE FROM UNDERSIDE. EXTRA WIDE OR EXTRA LONG (10' OR 12') SECTIONS SHOULD BE POSITIONED ON BRACKETS INDIVIDUALLY AND ASSEMBLED FROM UNDER SIDE.

6 Adjust countertop end alignment (see information above and on page 1) and screw brackets to countertop.

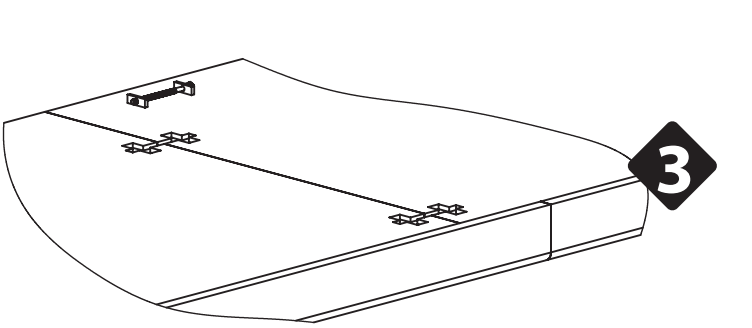
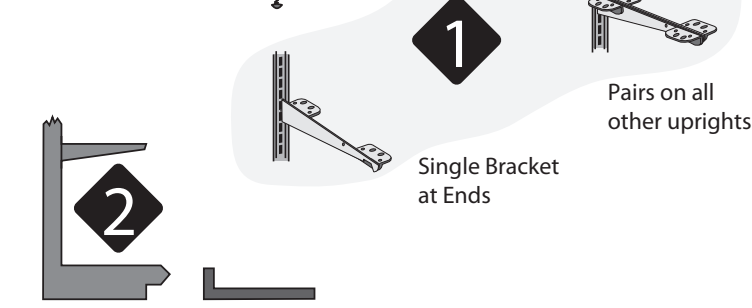
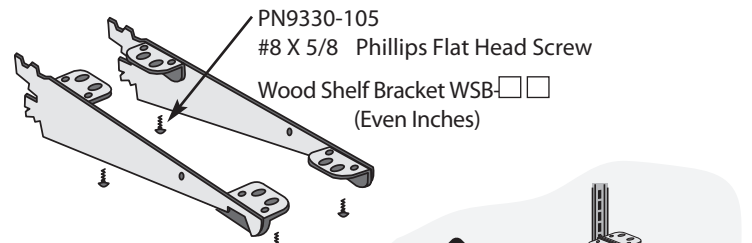

ASSEMBLY COMPLETE



P.O. BOX 729 / TERRELL, TEXAS 75160 / 972.563.5744 / 800.776.2349
 P.O. BOX 177 / GOODWATER, ALABAMA 35072 / 205.839.6354 / 800.633.6282

REV 1

REV#	ECN#	REVISION	BY	DATE
1	5*00000	UPDATED COUNTERTOP AND HARDWARE VIEW	CAB	04/04/2014