

MAXILINE WALL & GONDOLA GENERAL ASSEMBLY INSTRUCTIONS

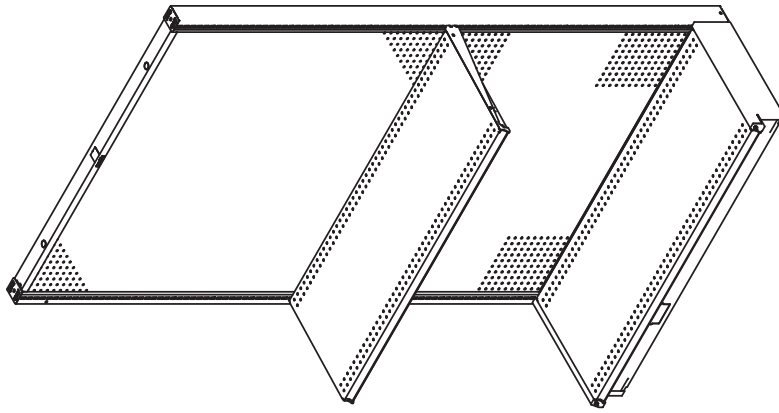

WALL
(10 - 17)

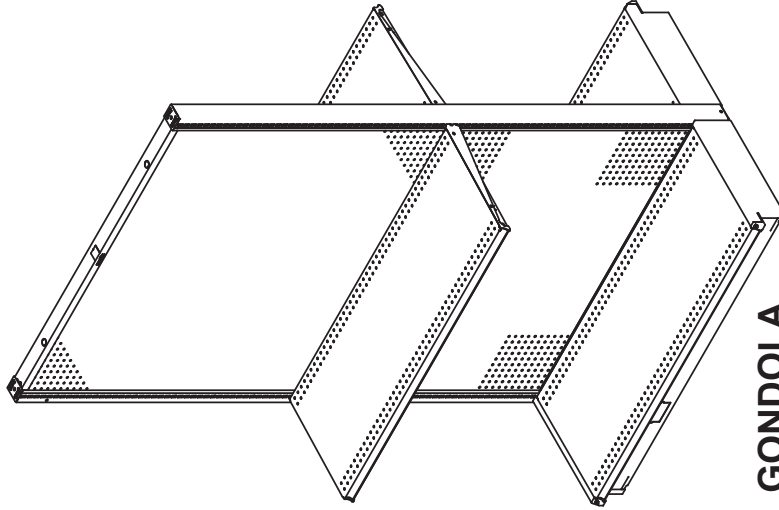

GONDOLA
(18 - 24)

The standard products listed below will alter the installation procedure. Refer to them prior to beginning installation.

BOX CORNER	ASY-098
CANOPIES	ASY-092
END MERCHANDISER	ASY-652
FLOOR ANCHORS	ASY-357
INSIDE CORNER	ASY-062
METAL END FLAT	ASY-269
OPEN BACK STIFFENER	ASY-042
OUTSIDE CORNER	ASY-059
OUTSIDE MOUNT END MERCHANDISER	ASY-064
STRAIGHT IN LOCKING BASE SHOE	ASY1-075
TELESCOPING UPRIGHTS	ASY-027
TRIPLE BACK SYSTEM	ASY-325
WALL END STABILIZERS	ASY1-292
WALL SECTION ADAPTER	ASY-066
WIRE GRID BACKS	ASY-328

! WARNING! This publication is intended to be a generic installation instruction and may be subject to change as required by the local building codes. Consult the building inspection department at the job site.

! WARNING! READ AND UNDERSTAND THIS DOCUMENT BEFORE PROCEEDING TO INSTALL SHELVING. SPECIAL ITEMS ARE DENOTED WITH:

! CAUTION!

! IMPORTANT!

! WARNING!



WARNING (For Wood Products Only): Drilling, sawing, sanding or machining wood products can expose you to wood dust, a substance known to the State of California to cause cancer. Avoid inhaling wood dust or use a dust mask or other safeguards for personal protection. For more information go to www.P65Warnings.ca.gov/wood.



INSTALLATION INSTRUCTIONS

THIS SUPPLIER PREEXISTING MATERIAL IS EXCLUSIVELY THE INTELLECTUAL PROPERTY OF MADIX INC.
ALL RIGHTS ARE RESERVED BY MADIX INC. © 2020
20884 AL HWY 19 GOODWATER, AL 36072 256-639-6354
PO BOX 728 TERRELL, TX 75160 214-515-5400

DWG NO.:

ASY-046

CHANGE #:

500000023154

DESC: GONDOLA / WALL FIXTURE

13

DATE: 20201005

DESIGNER: DBAILEY

SHEET 1 OF 25

PARTS

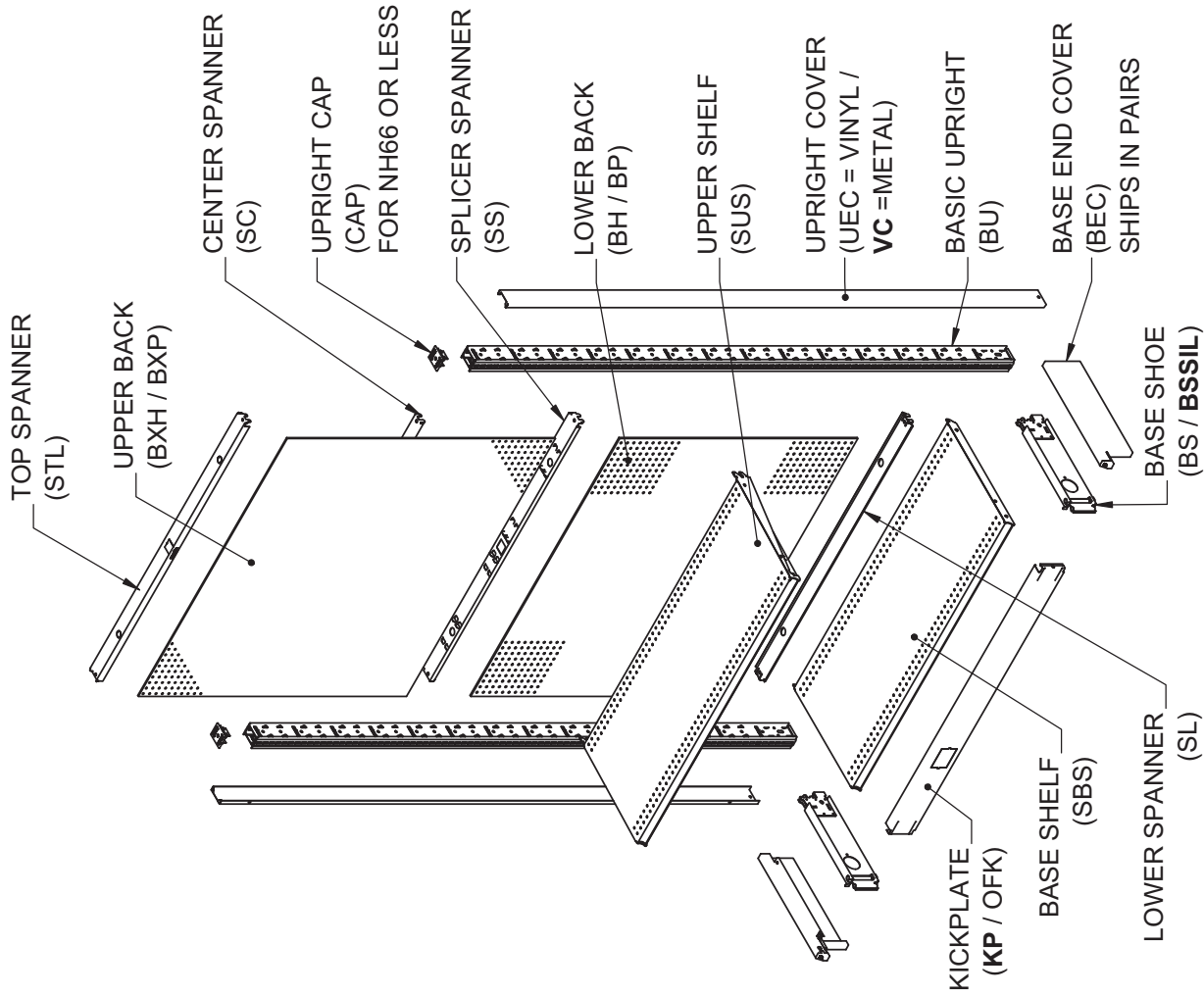

SPANNERS

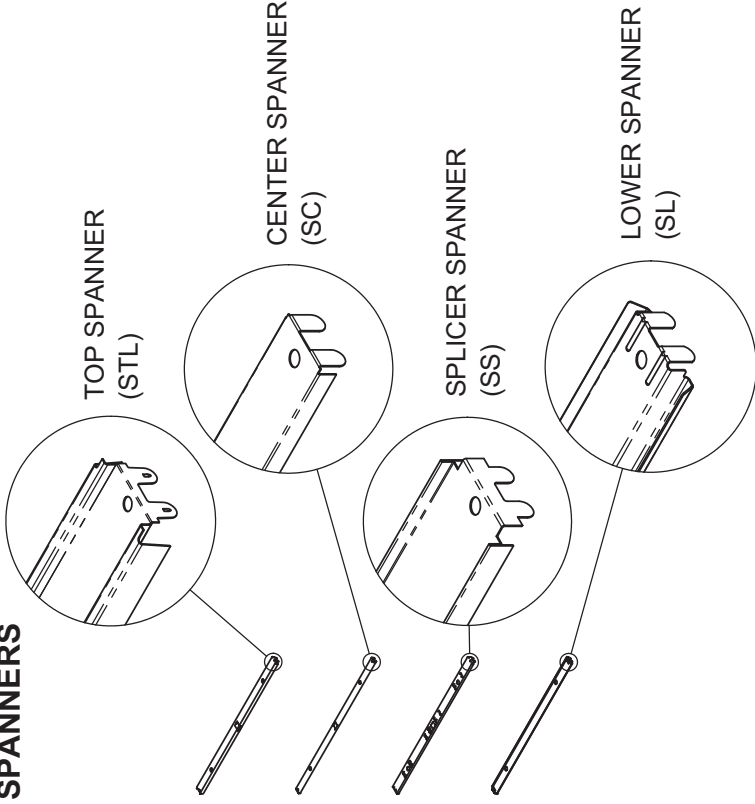

EQUIPMENT CHECKLIST

- ANCHOR BARS & STRING (GWSIK)*
- LEVELER WRENCH (LW-1)*
- CHALKLINE
- SCREWDRIVER (STANDARD)
- MAGNETIC LEVEL
- MEASURING TAPE
- RUBBER Mallet
- HAMMER



*MUST BE ORDERED INDIVIDUALLY

NH72 OR LESS = 1 BACK SYSTEM
 NH78 OR MORE = 2 BACK SYSTEM

SAFETY WARNINGS

POST THIS INFORMATION IN A LOCATION CLEARLY VISIBLE TO ALL STORE PERSONNEL

- Install all shelving and/or fixtures as described in installation instruction.
- Shelving and components should ONLY be installed by trained personnel who have read and understand these instructions. Failure to do so may result in product damage or personal injury.
- Do not exceed the maximum load capacities as outlined under all headings related to Load Limits or Capacities in this document.
- Never use damaged parts.
- Install and use components only as directed.
- Do not combine Madix products with non-Madix products unless approved by Madix.
- Always install Kick Plates (KP or OFK) to retain the structural integrity of the shelving. Kick Plates must be fully engaged in Base Shoes.
- Do not hang shelves, peg hooks or other accessories on the side of a fixture that does not have Base Shoes (BS or BSSIL) installed.
- Do not hang shelving, peg hooks or other accessories that exceed the depth of the base on a gondola or wall, even if fixture is anchored to the floor.
- All components that require trim, such as Uprights (BU) and Base Shoes (BS) should have trim installed to protect customers from potentially sharp edges.
- Never expose any sharp or pointed edges to shoppers or employees.
- Do not climb or stand on shelving.
- Provide safe access to all levels of shelving according to OSHA regulations.
- Do not move assembled shelving.
- Do not move a shelf with merchandise on it.
- Do not off load a side of a 2-sided gondola without checking for unbalanced load.
- Do not lean heavy items against shelving.
- All End Panels (EP) and other panels for merchandising or aesthetics must have bases or lower shelves within 27" of the floor in order to direct traffic away from protrusions.
- **NEVER STACK EXTENSION UPRIGHTS (EU)**. Do not exceed maximum load capacity on EU. Maximum load capacity for EU is 2500 in/lb unbalanced per section. SEE ASY-018 FOR EU INSTALLATION.
- Furring strips must be secured to the wall stud to be effective. Each fastener securing the furring strip to the wall must withstand 400 lb of pullout force.

IMPORTANT!

To clean Madix shelving, use of a non-abrasive mild detergent and warm water, followed by thorough drying is ideal. Use a cloth made of a soft, white cotton material. The use of cleaning agents that contain abrasives, bleach, or strong solvents such as ketones, ethers etc. will result in damage to the finish. The damage is most severe when these harsh cleaning agents are used on colors which contain aluminum pigment such as powder chrome, silver vein and other "vein" type finishes. As an alternative to the mild detergent, cleaners with ingredients similar to those found in products such as 409, Fantastik, and Simple Green can be used. **CAUTION!** Cleaners having ingredients similar to those found in Ajax, Borax, Bleach, Comet, etc. should be avoided as finish damage could result.

CAUTION!

LOAD CAPACITY FOR PEGBOARD BACKS:

- MAX 150 lb per side** with SL lower spanner in place.
- MAX 300 lb per side** with HSL Heavy Duty Lower Spanner.
- MAX 15 lb per peg hook.**



THIS SUPPLIER PREEXISTING MATERIAL IS EXCLUSIVELY THE INTELLECTUAL PROPERTY OF MADIX INC. ALL RIGHTS ARE RESERVED BY MADIX INC. © 2020

PALLET LABEL LAYOUT

When unloading, stack all boxes...

1. with the **LABELS VISIBLE**
2. with the **SAME DESCRIPTION** together
3. with the **SAME PART NUMBER** together

PALLET #

1234567899

CUSTOMER P.O.

CUST PO#: 1234567899

SHIP TO ADDRESS

WT: 70.500

PALLET WEIGHT

Delivery: 12345678

Print Date: 01/01/2021 12:00:00

ORDER:

1234567

FROM: MADIX STORE FIXTURES

TO: CUSTOMER NAME

201 SKYLINE DR

TERRELL TX 75160

STREET NAME
CITY
STATE

Open

01/01/2021

CARRIER: CUSTOMER ARRANGED - TL

TL MF: MARK FOR

SHIP DATE

CARRIER

QTY UOM ITEM# / DESCRIPTION / COLOR

QUANTITY ON PALLET

5

EA

EPPH -- 430 -- SW

EXTENDED PANEL PEGBOARD HEAVY DUTY FRAME

SW

MATERIAL #

MATERIAL DESCRIPTION

MATERIAL COLOR(S)

PALLET: Box/Palletize

Madix, Inc 01/2021 TSCA Title VI Compliant

PACK TYPE REQUEST

TL = TRUCK LOAD
LTL = LESS THAN TRUCK LOAD

HEIGHT TO DEPTH RATIO

If the height of the Upright exceeds six times the space between the Upright and Base Shoe leveler on a wall unit or between Base Shoe levelers on an island, the system must be secured in one of the following ways:

- For Walls, secured at the Base Shoe Levelers AND Upright Levelers must be anchored to the floor or to an adjacent building wall (see sheet 16).
- For Gondolas, Base Shoe Levelers must be anchored to the floor as shown in ASY-357 or as mandated by a seismic engineer if being installed in a seismic region.

WALL (UNANCHORED)

BASE SHELF DEPTH (in)	LEVELER SPACING (in)	UPRIGHT MAX HEIGHT (in)
12	9.5	54
14	11.5	66
16	13.5	78
18	15.5	90
20	17.5	102
22	19.5	114
24	21.5	120
26	23.5	138
28	25.5	144
30	27.5	162

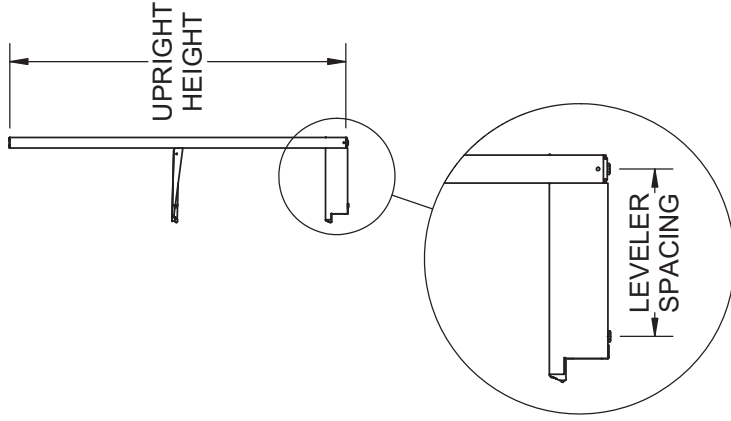

GONDOLA (UNANCHORED)

BASE SHELF DEPTH (in)	LEVELER SPACING (in)	UPRIGHT MAX HEIGHT (in)
12 & 12	19	114
12 & 14	21	126
14 & 14	23	138
14 & 16	25	144
16 & 16	27	162

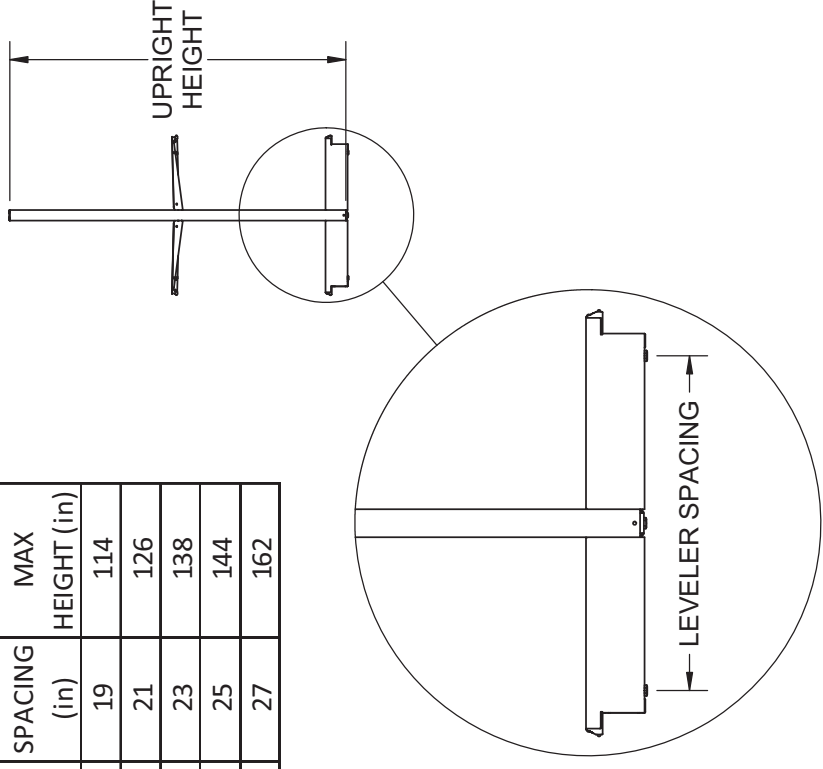

SHELF LOAD LIMITS



SUS, DEPTH: 06 - 18



SUS, DEPTH: 24 - 30



STP, DEPTH: 06 - 18

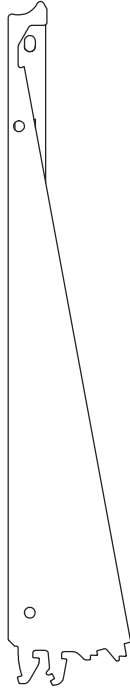

STP, DEPTH: 20 - 30

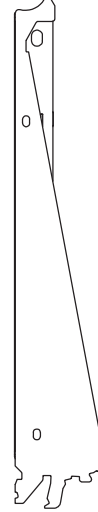

HUS, DEPTH: 16 - 19

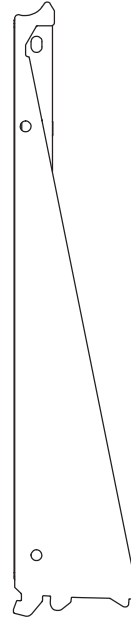

HUS, DEPTH: 20 - 30



SBS, DEPTH: 12 - 30

SHELF TYPE	MAXIMUM LOAD CAPACITY* IN POUNDS			
	SHELF DEPTH	FLAT EVENLY LOADED	15° DOWN	30° DOWN
SUS	06 - 08	300	125	100
	08 - 18	500	125	100
	20 - 24	500	250	100
	26 - 30	400	200	100
STP	06 - 08	300	250	100
	10 - 18	500	250	100
	20 - 24	500	250	100
	26 - 30	400	200	100
HUS	16 - 18	600	N/A	N/A
	20 - 30	600	N/A	N/A
SBS	12 - 30	600	N/A	N/A

*Based on evenly distributed static loading.



WARNING!

Capacities are reduced by 35% when only the front half of the shelf is loaded.

Capacities are only for shelves installed on Maxi Shelving System.

UNBALANCED LOAD CALCULATION

To determine the unbalanced load on the system, multiply the **weight on each Shelf (lb)** by **1/2 the Shelf depth (in)**. Add up the total load per side (in-lb).

Then find the difference between the load on each side.

CAUTION! DO NOT exceed a difference of 15,000 in-lb.

Load on base shelves does not contribute to the unbalanced load and can be ignored.

IMPORTANT!

Front loaded shelves create a more severe unbalanced load.

These are shelves that have most of the merchandise sitting near the front of the shelf. In this case the system load rating needs to be reduced by 35% (10,000 in-lb).

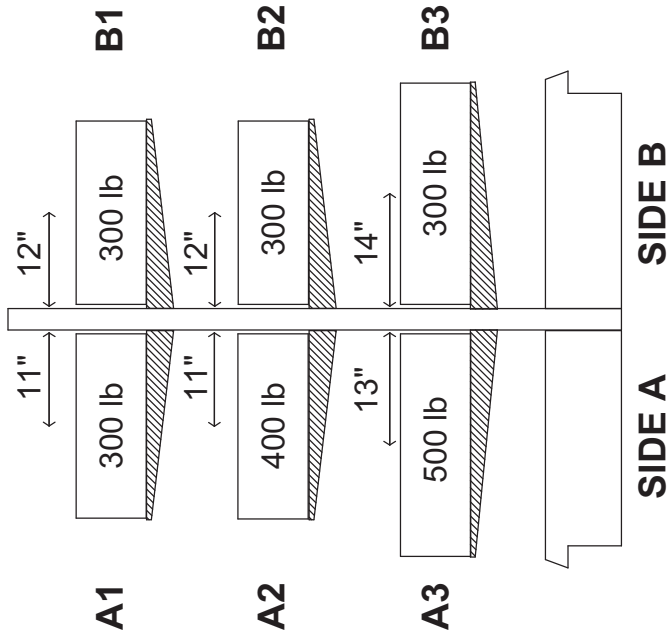

A1	11"	x	300 lb	=	3,300 in-lb
A2	11"	x	400 lb	=	4,400 in-lb
A3	13"	x	500 lb	=	6,500 in-lb
SIDE A				=	14,200 in-lb
B1	12"	x	300 lb	=	3,600 in-lb
B2	12"	x	300 lb	=	3,600 in-lb
B3	14"	x	300 lb	=	4,200 in-lb
SIDE B				=	11,400 in-lb

SIDE A	14,200 in-lb
SIDE B	- 11,400 in-lb
	2,800 in-lb

2,800 in-lb < 15,000 in-lb
So, the fixture is safely loaded

COLUMN LOAD CALCULATION

Column loading is the vertical load that can be applied on any upright.

Each Upright bears one half of the load of each shelf that it supports since each shelf is installed onto 2 Uprights.

CAUTION! Maximum column load is 4,500 lb

GONDOLA

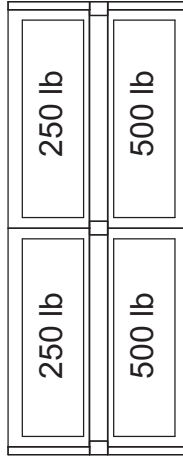

TOP VIEW

Column load on Center Upright:

250 lb	
500 lb	
250 lb	
500 lb	
1,500 lb / 2 = 750 lb	

WALL

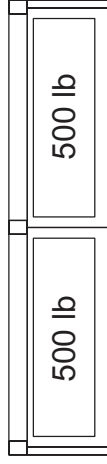

TOP VIEW

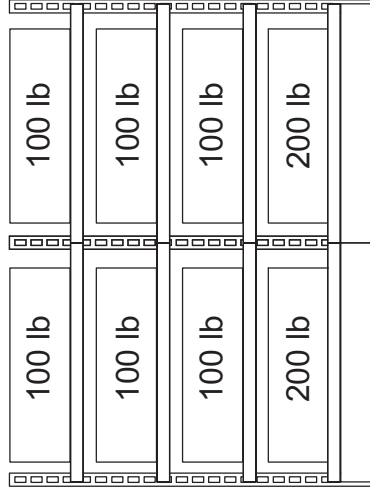

FRONT VIEW

Column load on Center Upright:

500 lb	
500 lb	
1,000 lb / 2 = 500 lb	

BACK PANEL IDENTIFICATION

See ASY-325 for Triple Back Systems
 See ASY-328 for Wire Grid Backs

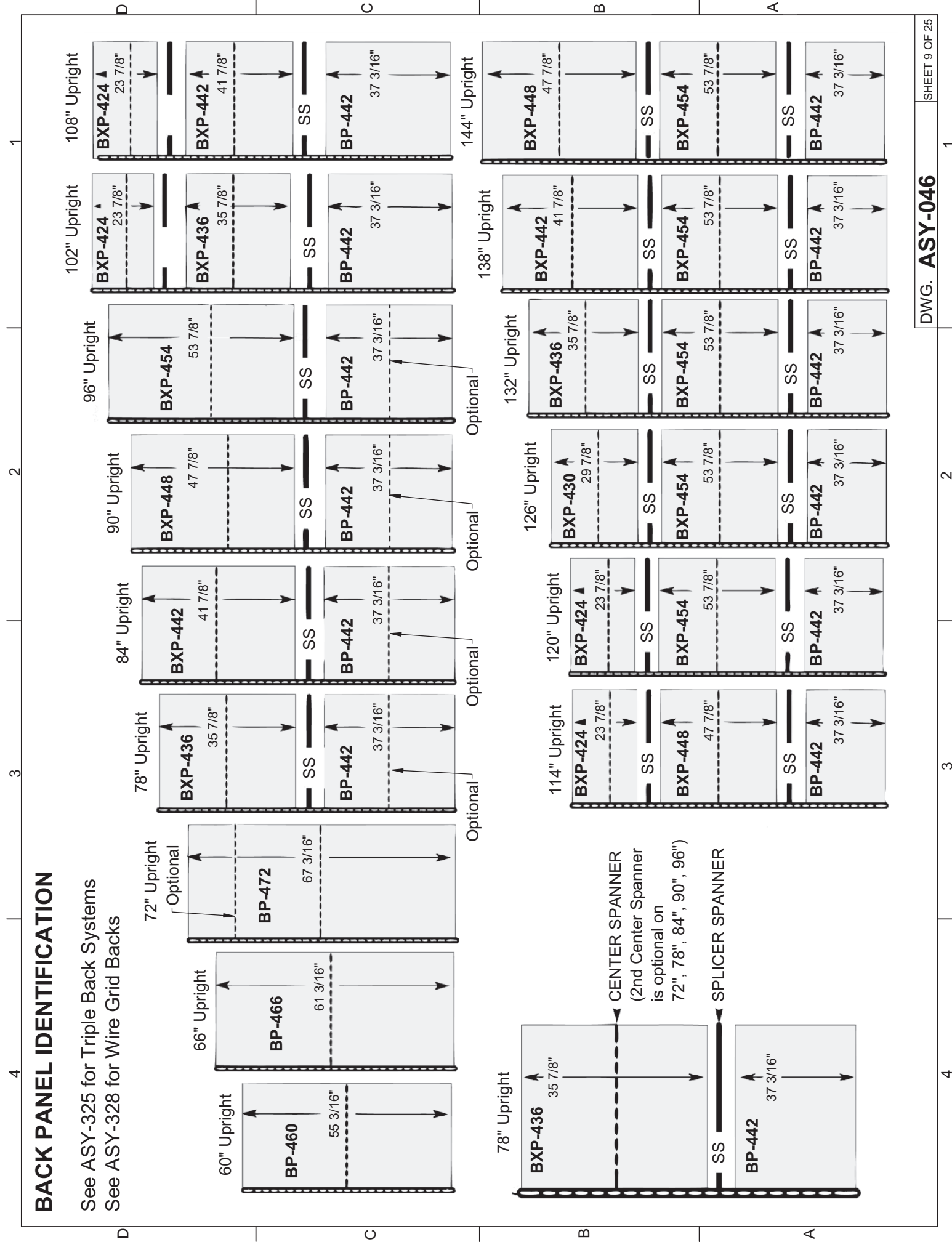

WALL SECTION INSTALLATION

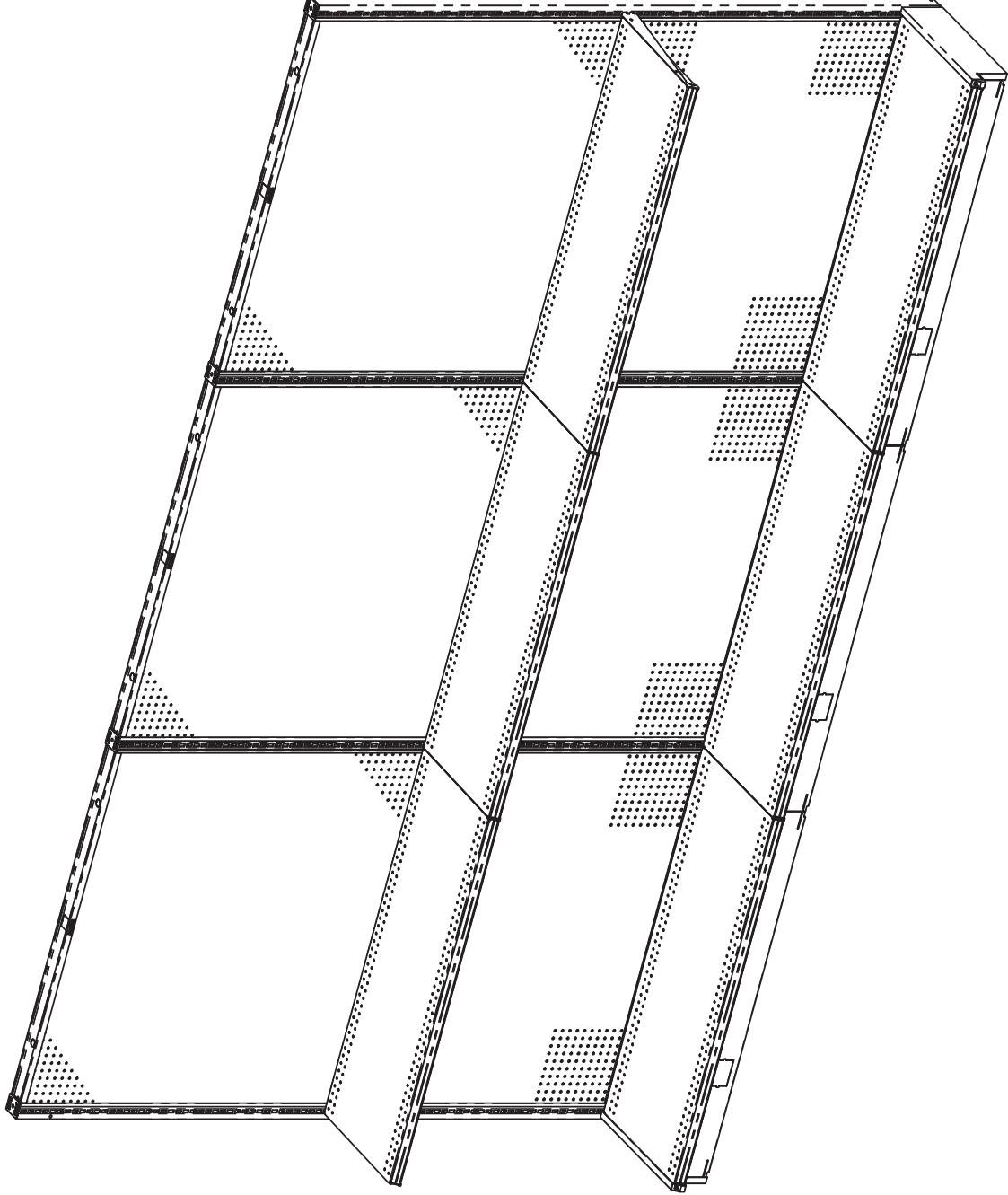

STEP 1 Snap chalkline on floor in desired location of shelving run. It should indicate where the Kick Plates will be.



Note: Shelf will overhang Kick Plate by 1 5/8"

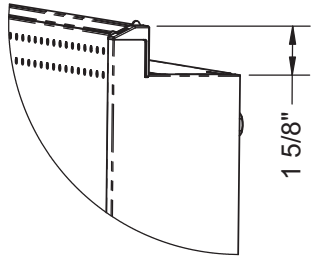

STEP 2 Lay out parts along chalkline as shown.

STEP 3 At this point you will need two Back Panels close by for the first and last section of each wall run.

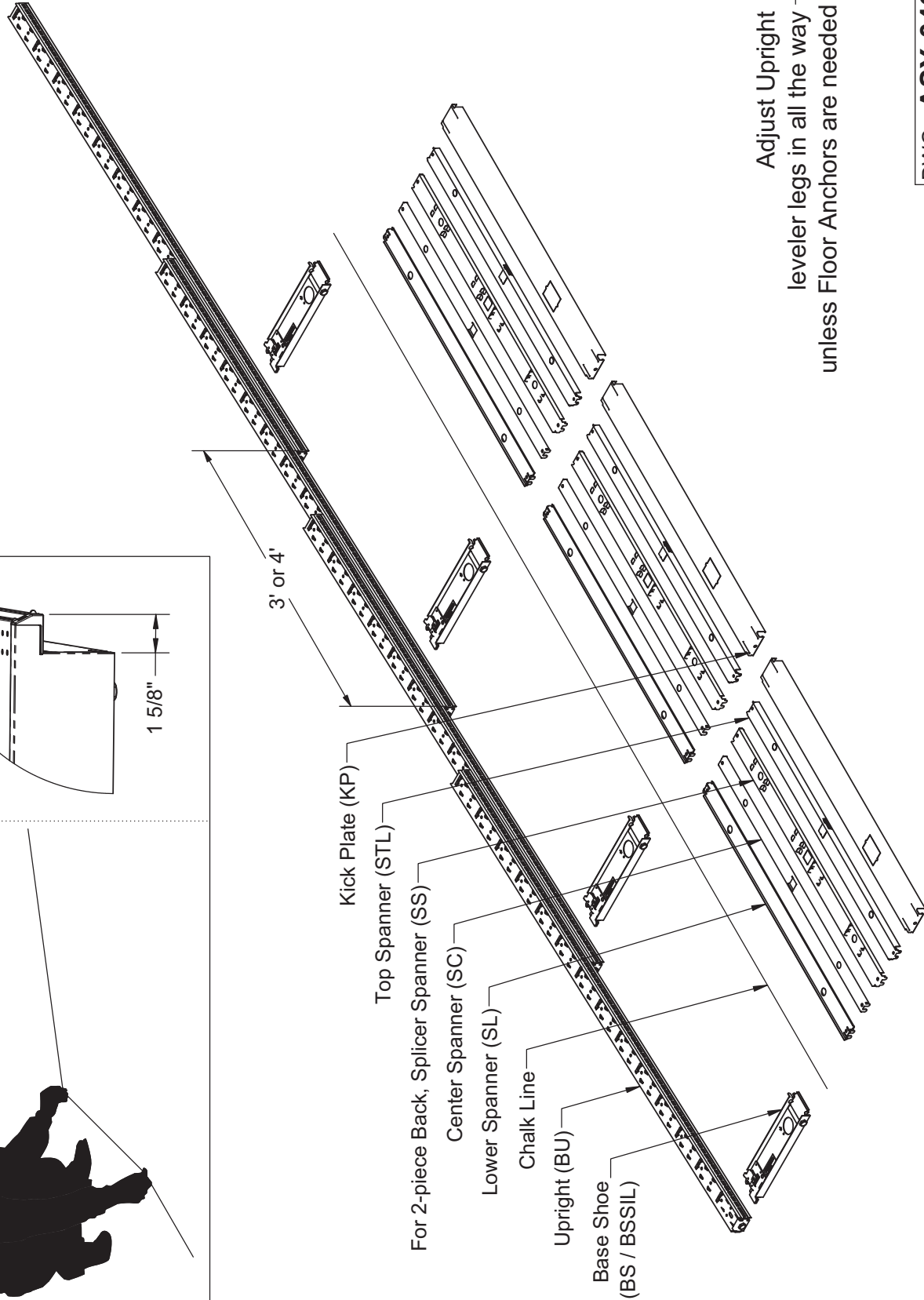

Adjust Upright leveler legs in all the way unless Floor Anchors are needed

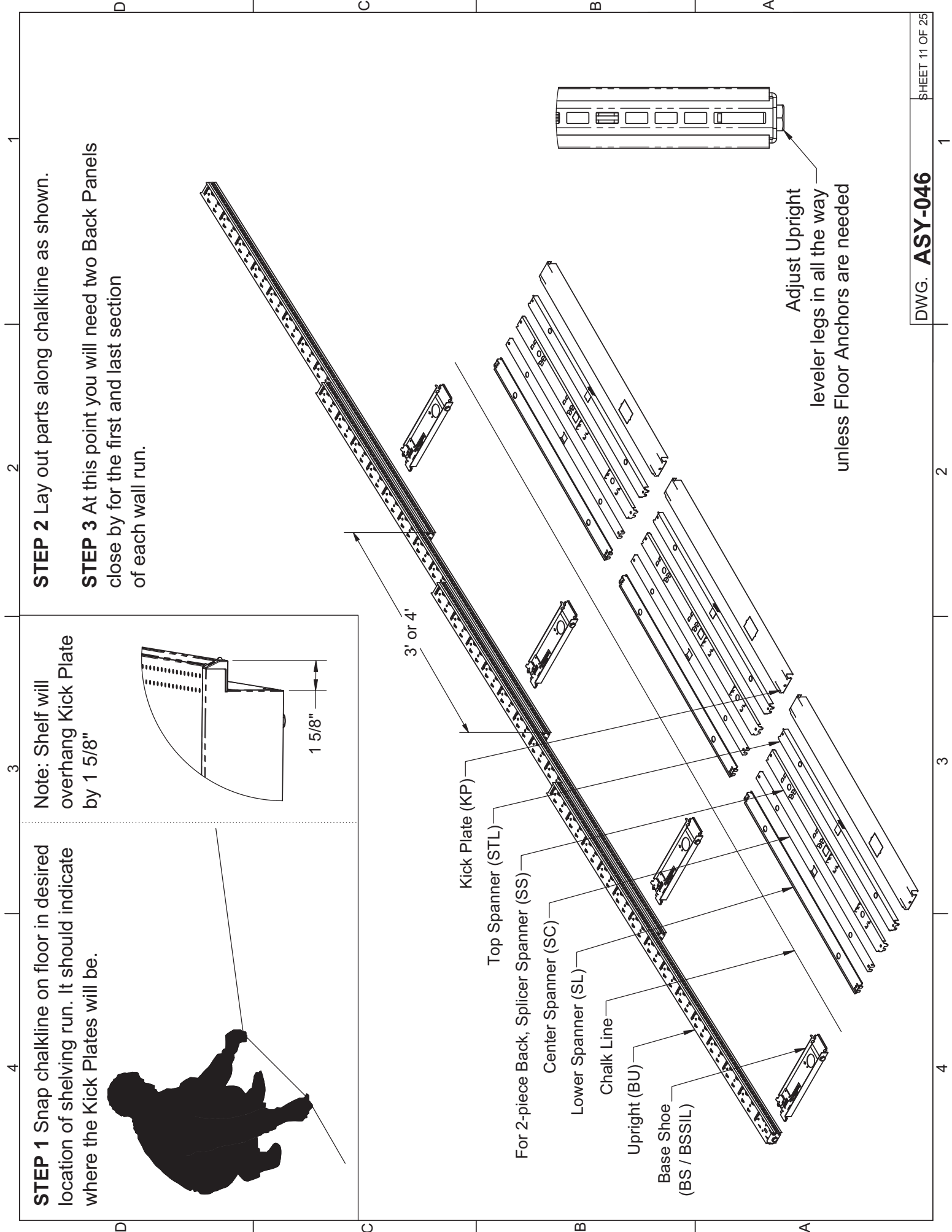

STEP 4 Install Base Shoes, either **BS** or **BSSIL**

BS (Base Shoe) Installation

Note: BS has been discontinued & can no longer be ordered

Hook Base Shoes bracket into Upright slot as shown

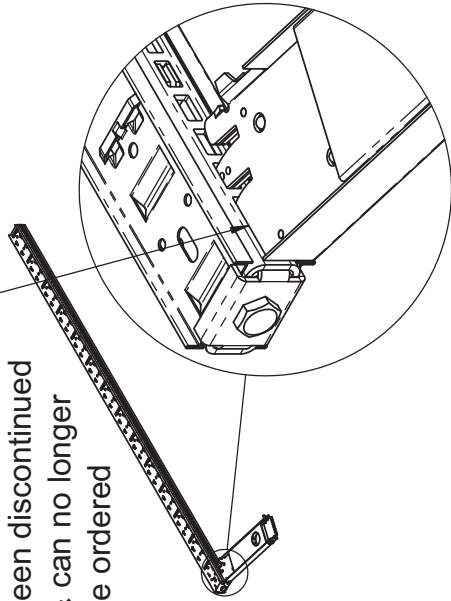

Raise Upright vertically, then push down sharply against the floor to lock in Base Shoe.

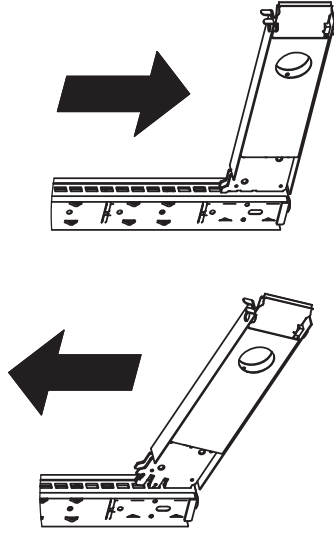

Drive in pins on all Uprights

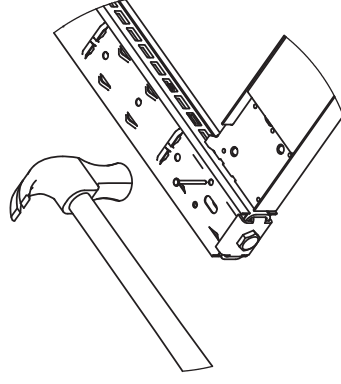

BSSIL (Base Shoe Straight-in Locking) Installation

Align bracket with Upright and insert Shoe

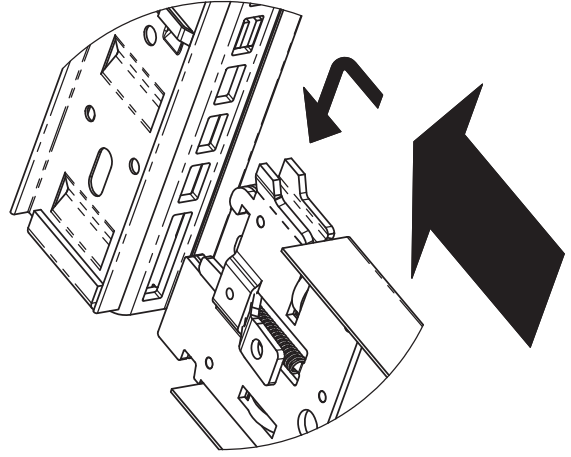

Slider will **CLICK** if properly installed

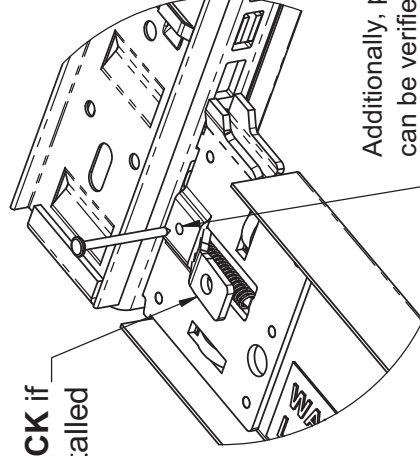

Additionally, proper engagement can be verified by making sure that this hole is clear all the way through the Shoe. Use WSRP pin to check.

STEP 5 Install Lower Spanner on the lowest lance of the Upright

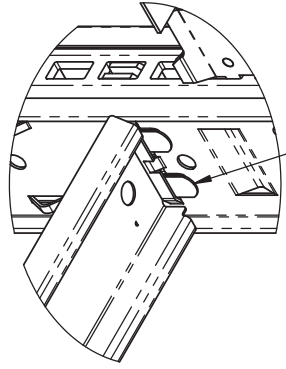
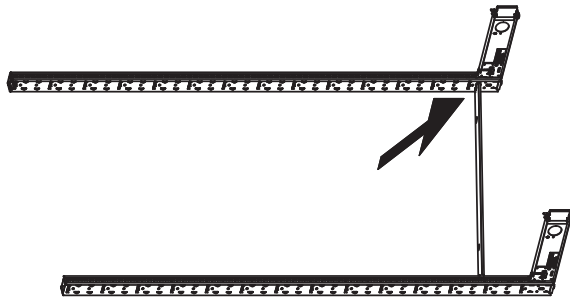

Both Spanner tabs must be showing below lances

STEP 6 Install Center Spanner at approximate midpoint of Back

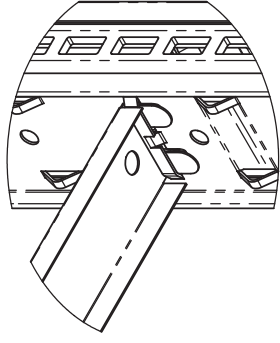
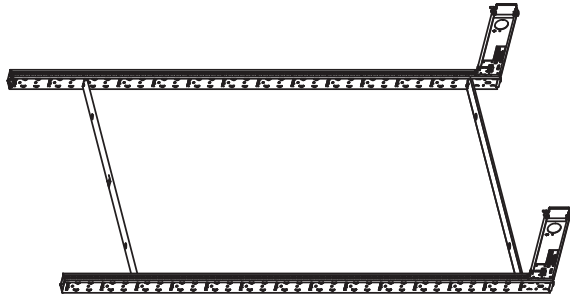

STEP 7 Install the Back panel. Slide down from top onto the Lower Spanner.

CAUTION!
Do not drop Backs. It may result in damage to the Lower Spanner.

WARNING!
Never allow framework to stand alone until a Back panel is in place. Framework may fall and may cause injury or damage components!
Center & Bottom Spanners must be installed.

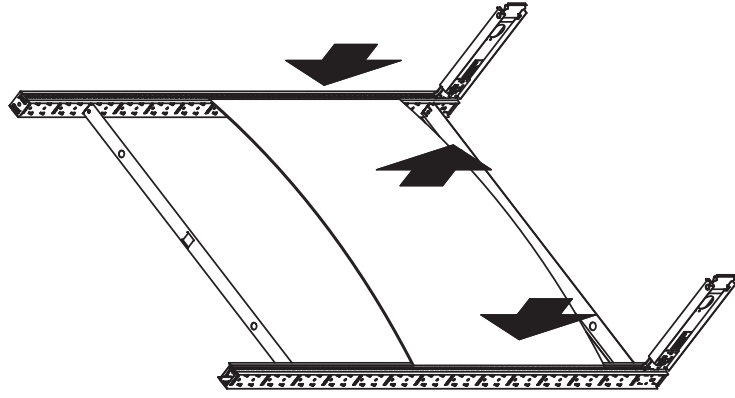

If low ceiling clearance prevents installation of Back panels from top, Back panels may be bowed slightly and flexed into Uprights.

Be careful not to damage Back panels.

STEP 8 Stand remaining Uprights in run, installing Center and Lower Spanners between the Uprights.

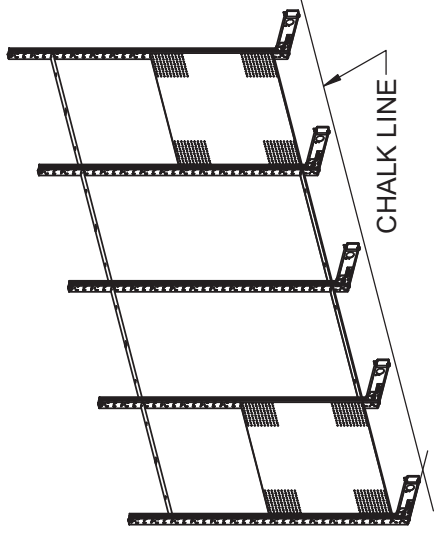

CHALK LINE

If run is 8 sections or less, install one Back into first and last sections to square before leveling. If gondola is more than 8 sections then additional Back(s) will need to be installed in center of run for additional stability.

STEP 9 Install all Kick Plates. Either snap in from the front or slide down from the top

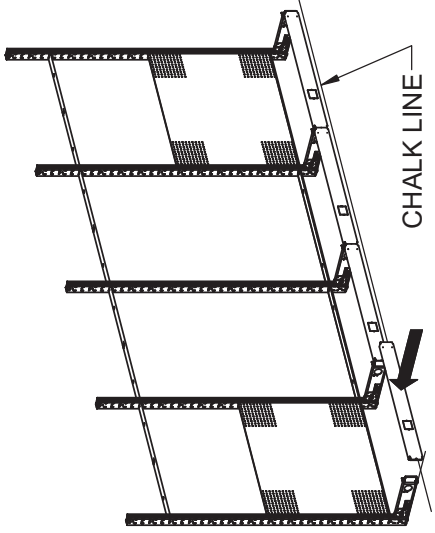

CHALK LINE

STEP 10

Raise both end Uprights using Upright levelers approximately 1/2" and **plumb** Uprights with magnetic level against the face of the Upright using the Base Shoe and Upright levelers. Both ends should be at the same height.

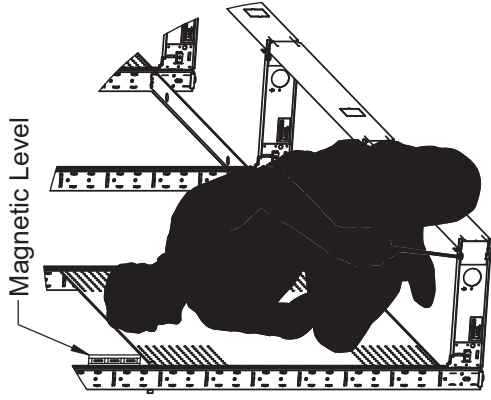

Magnetic Level

WHAT IS PLUMB?

Use magnetic level against Upright face to verify

90°

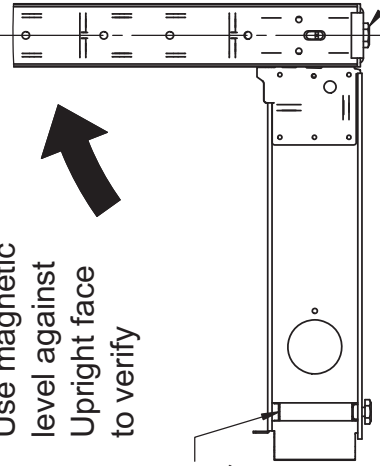

Adjust Shoe leg with screw driver

Adjust Upright leg with Leveler Wrench. Leg must touch floor after plumbing

SCALE 1 : 16

BASE SHOE LEVELER LEGS

Use shims if needed

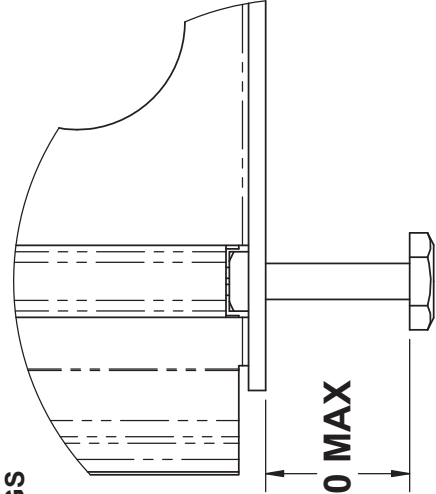

1.500 MAX

SCALE 1 : 3

STEP 11 Attach the nylon string to end Upright with GWSIK as shown. Attach line at corresponding slot on opposite end Upright. Draw taut and secure

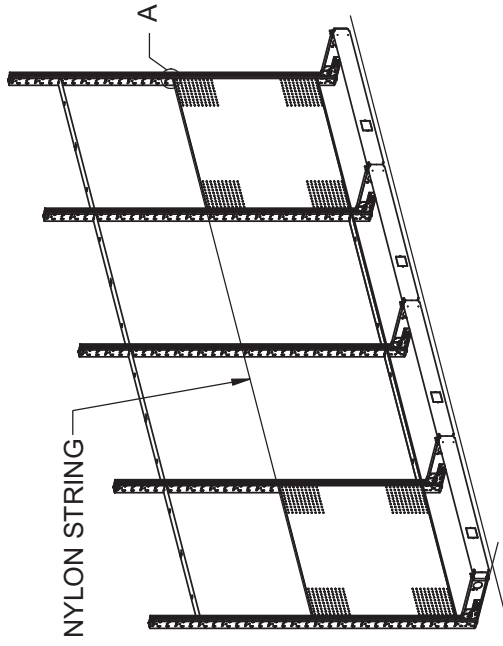

SCALE 1 : 48

Customer must specifically order Gondola / Wall Section Installation Kit (GWSIK) . It includes nylon string & bars to anchor string.

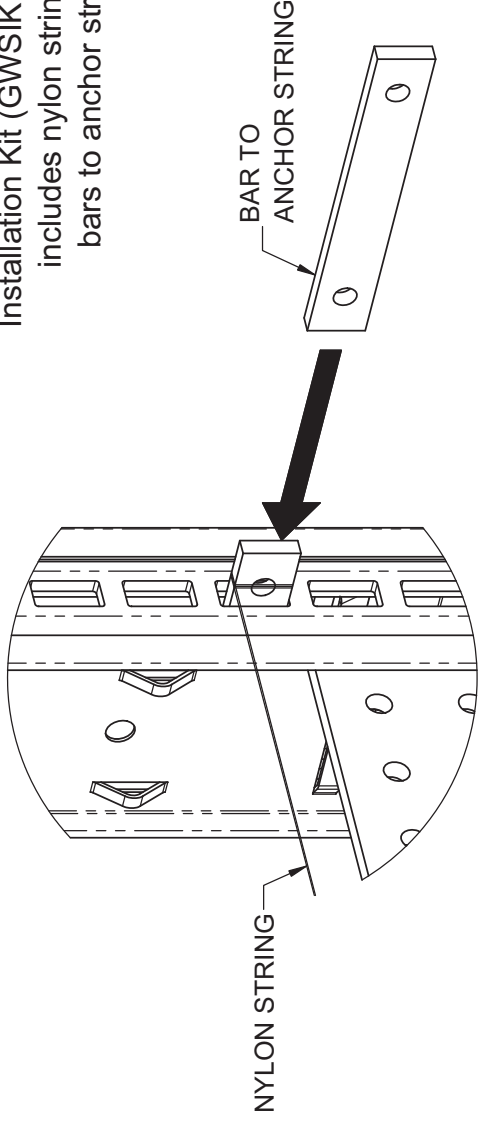

DETAIL A
SCALE 1 : 2

STEP 12 Examine all center Uprights at nylon string to determine the highest Upright in the run. If the highest Upright is below the string line then bring it up to the stringline using the Upright leveler and plumb using the leveler in the Base Shoe leveler. If it is above the string line it will be necessary to go back and raise both the end Uprights to match that high spot.

STEP 13 Now raise the remaining Uprights in succession to match the string line using the Upright leveler and **plumb** each upright using the Base Shoe and Upright levelers and a magnetic level against the face of the Upright. Make sure Kick Plates are on chalkline and all Upright & Base Shoe levelers are touching the floor.

SLOT ALIGNMENT

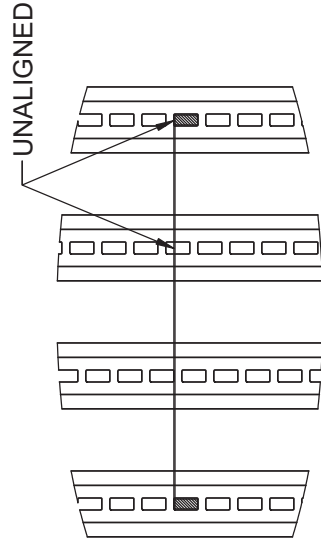

BEFORE

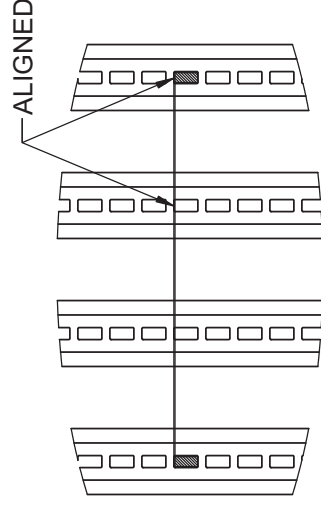

AFTER

STEP 14 At this time, anchor wall sections if required

If canopy is to be used, see ASY-092 prior to proceeding

AVAILABLE ANCHORING COMPONENTS

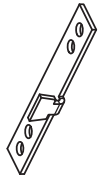

Basic Upright Wall Mount Support (BUWMS)

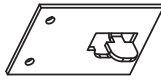

Half Basic Upright Wall Mount Support (BUWMS-HALF)
For end of runs

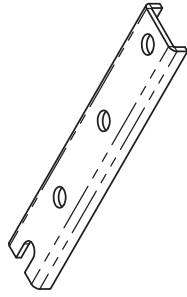

Heavy Duty Floor Anchor (SFA-HD GAL)

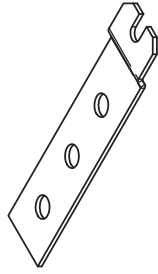

Regular Duty Floor Anchor (SFA-RD)

Review ASY-357 for Floor Anchor instructions. The type of Anchor is based on the need for the location as it relates to seismic requirements. In addition, if the Upright to Base Shoe ratio exceeds 6 : 1, then Floor Anchors are recommended.

WARNING: Furring strips must be secured to the wall stud to be effective. Each fastener securing the furring strip to the wall must withstand 400 lb of pullout force.



FURRING STRIP DIAGRAMS

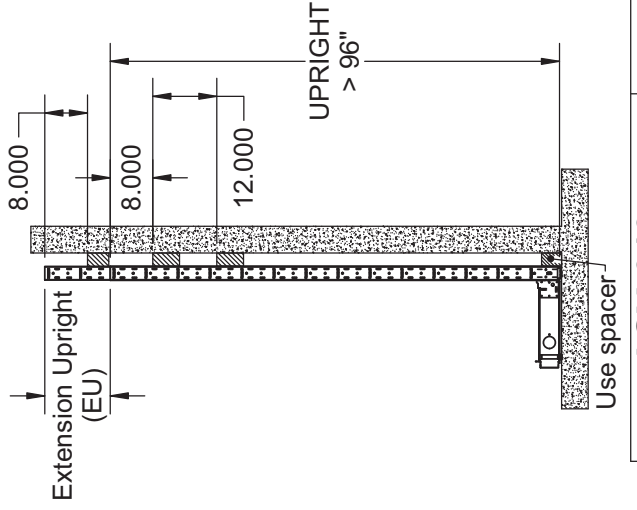
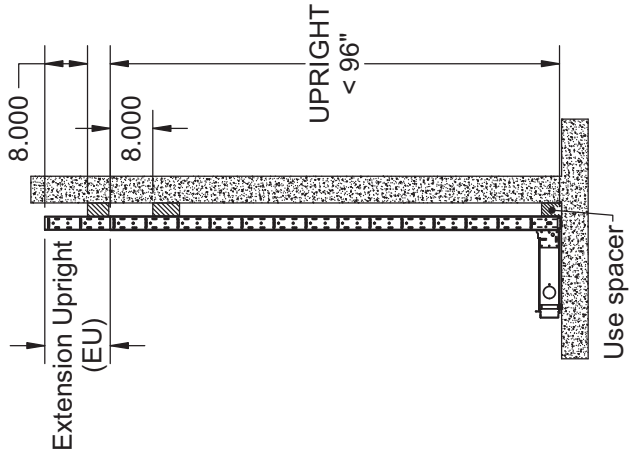
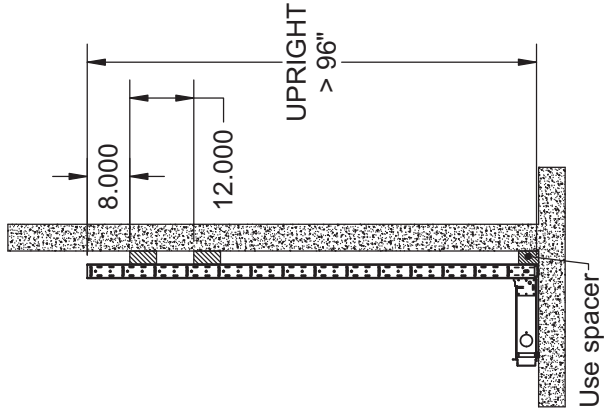
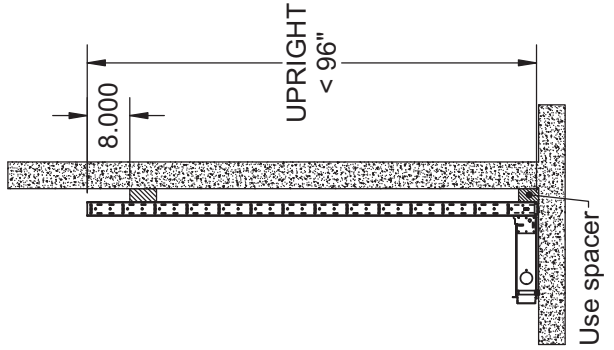

4 3 2 1

STEP 15 Remove the nylon string and install all lower Back panels in the run.

STEP 16 Install Splicer Spanners in lances between upper and lower Back if a 2-piece Backs are required.

STEP 17 Install remaining upper Back panels.

STEP 18 Install Top Spanners. Make sure locking tabs rest below first lance as shown.

STEP 19 Install Upright End Covers. Hook over top of Upright, then press on working toward the floor. UEC is vinyl and VC is metal.

STEP 20 For Uprights 66" or shorter, install Upright Caps so that the short plastic extrusion is captured in the slot at top of the Upright End Cover while tabs snap behind top lance.

STEP 21 Install the Base End Covers over the Base Shoes so the Shoe tab is through slot in the Cover.

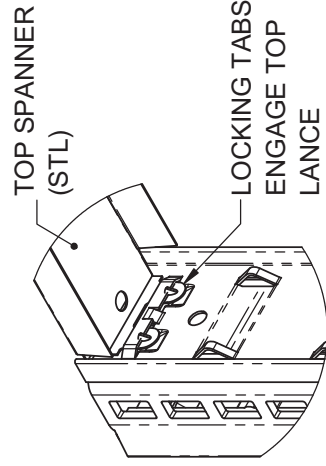

STEP 18

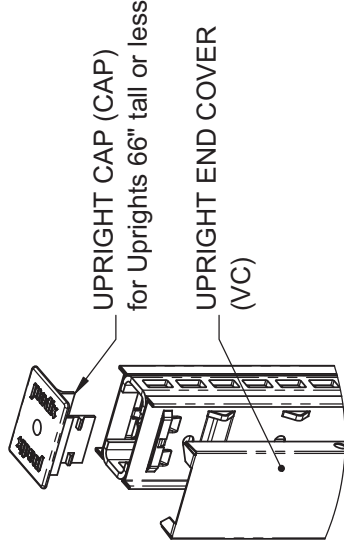

STEP 19 & 20

CAUTION!
DO NOT DROP BACKS
MAY DAMAGE SPANNERS

Shoe tab to retain Cover

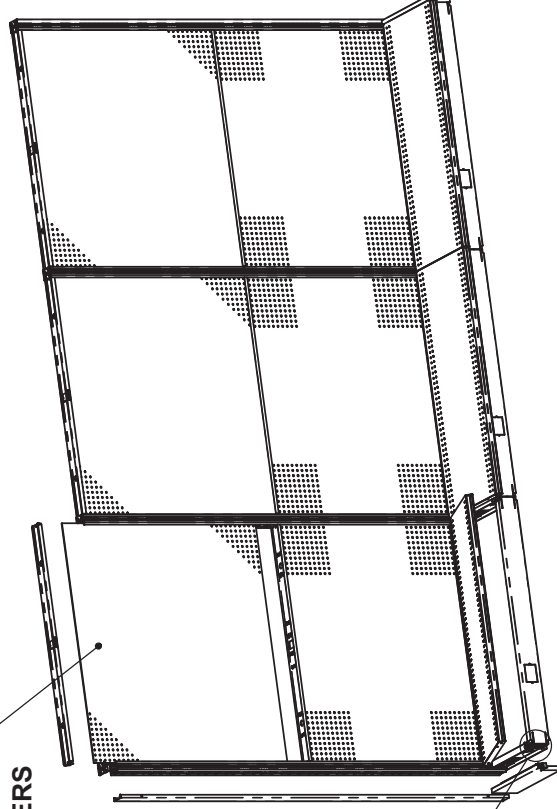

STEP 21

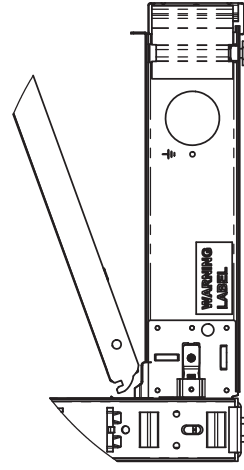

STEP 22

STEP 22 Install Base Shelves. Engage shelf bracket into the lowest Upright slot available and rest on top of Base Shoes.

STEP 23 Install Upper Shelves and all accessories (not shown).

4 3 2 1

GONDOLA SECTION INSTALLATION

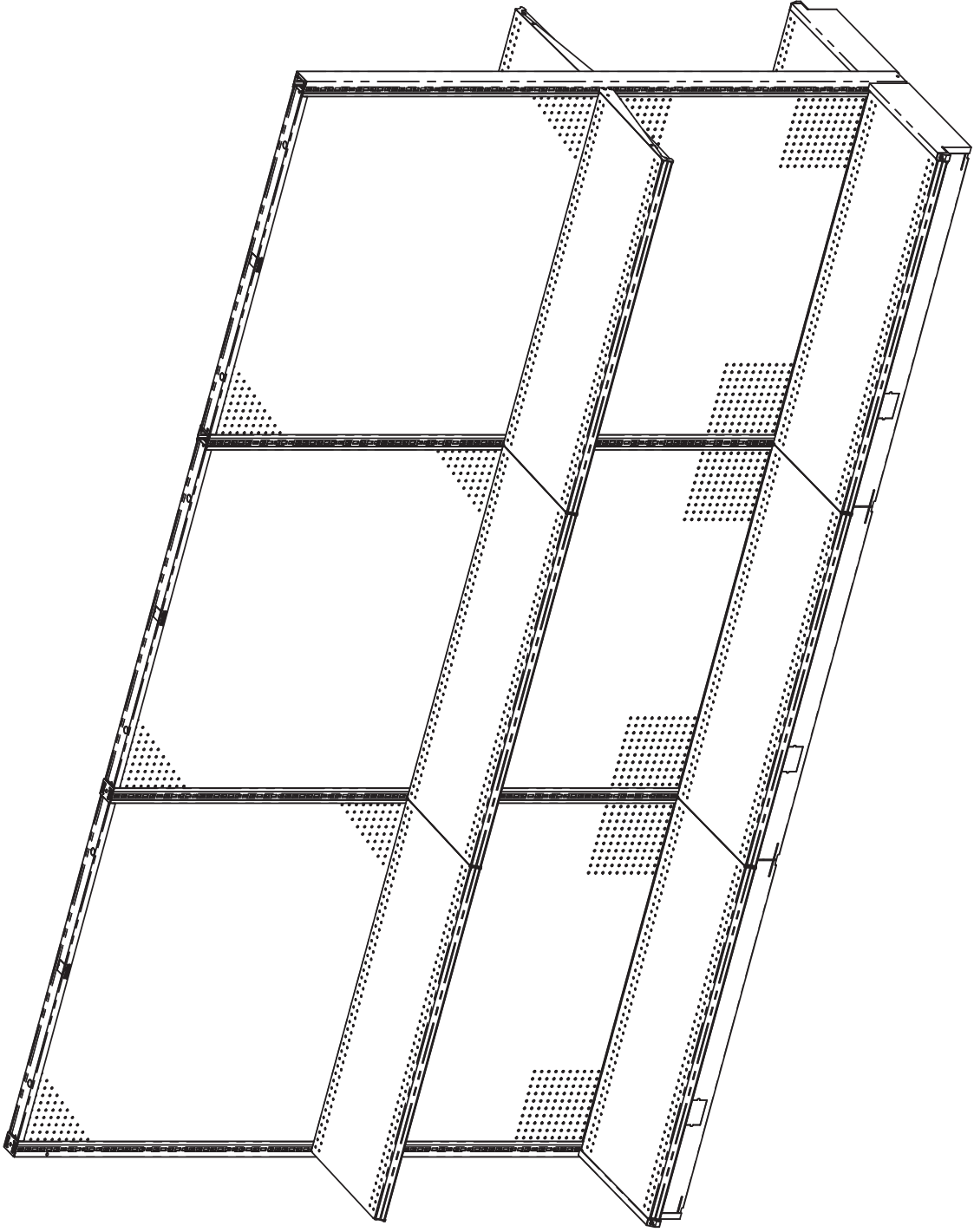

STEP 1 Snap chalkline on floor in desired location of shelving run. It should indicate where the Kick Plates will be.

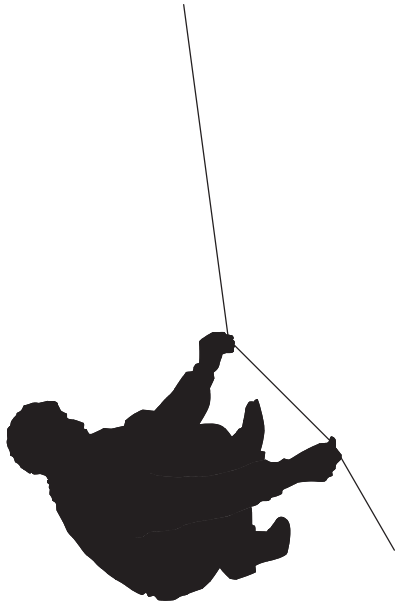

Note: Shelf will overhang Kick Plate by 1 5/8"

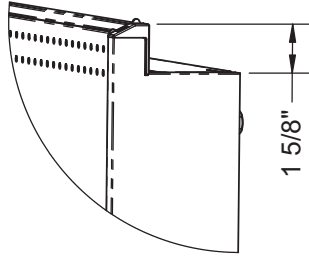

STEP 2 Lay out parts along chalkline as shown.

STEP 3 At this point you will need two Back Panels close by for the first and last section of each gondola run.

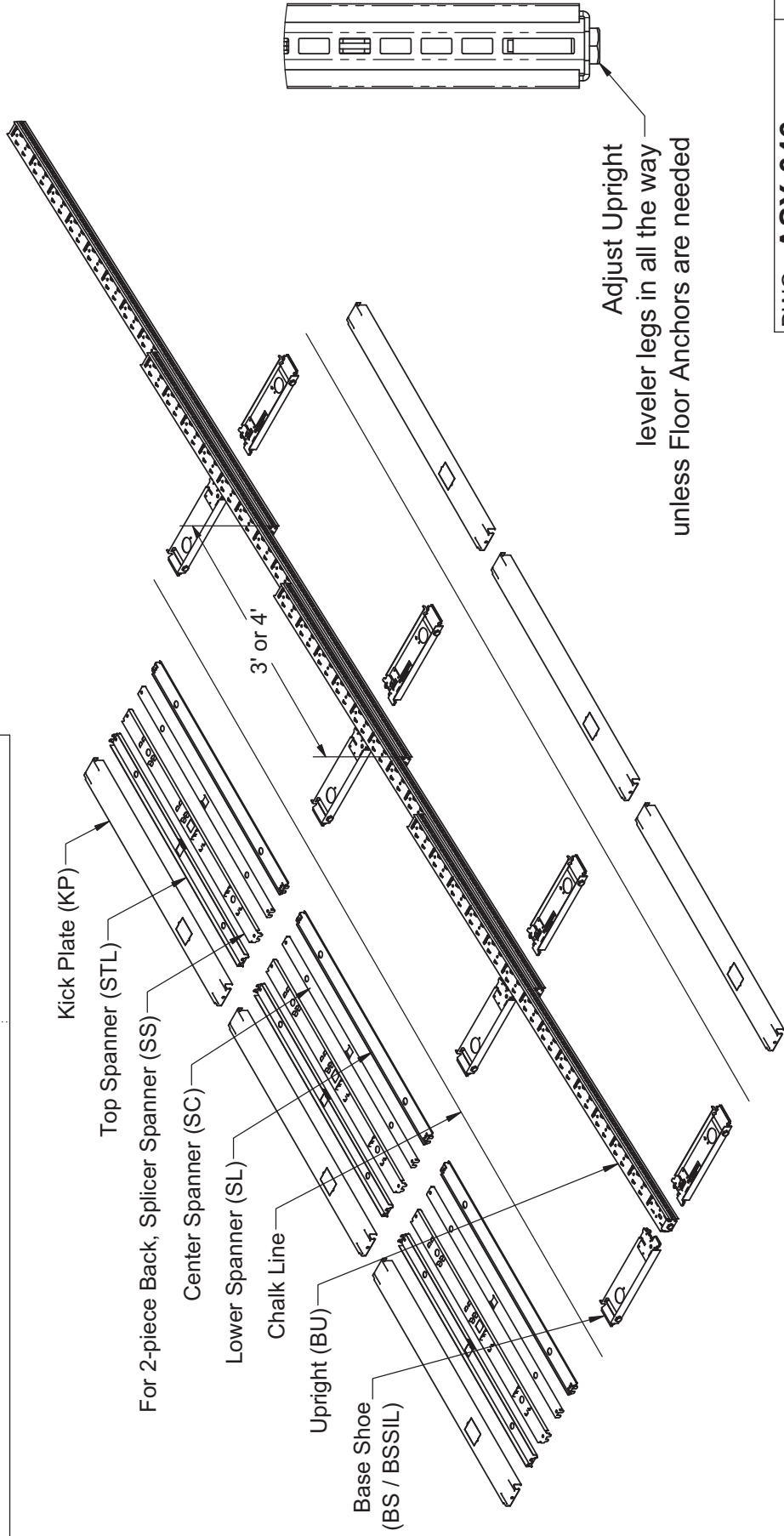

STEP 4 Install Base Shoes, either **BS** or **BSSIL**

BS (Base Shoe) Installation

Note: BS has been discontinued & can no longer be ordered

Hook Base Shoes bracket into Upright slot as shown

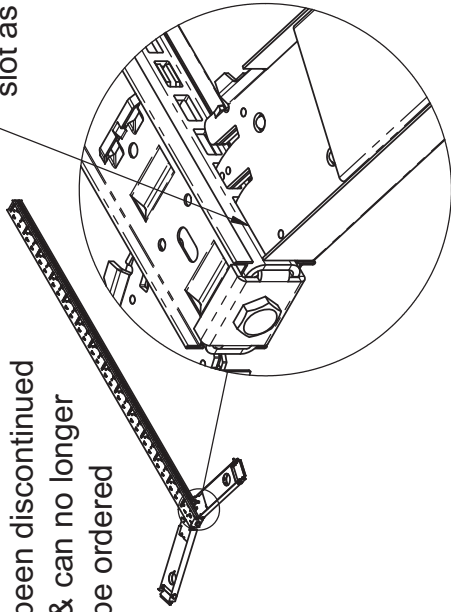

Raise Upright vertically, then push down sharply against the floor to lock in Base Shoe.

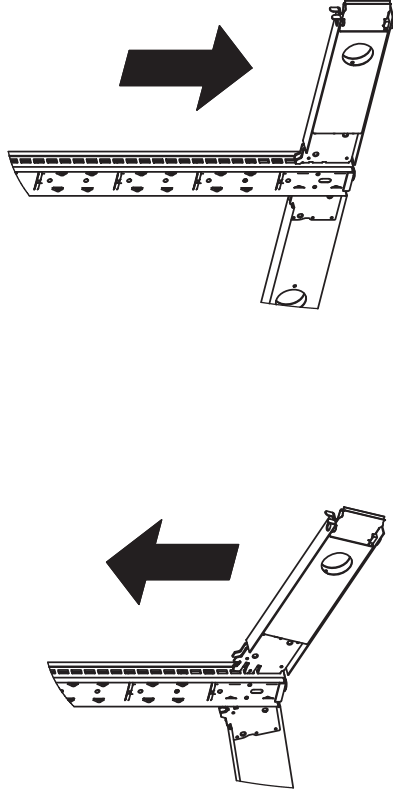

BSSIL (Base Shoe Straight-in Locking) Installation

Align bracket with Upright and insert Shoe

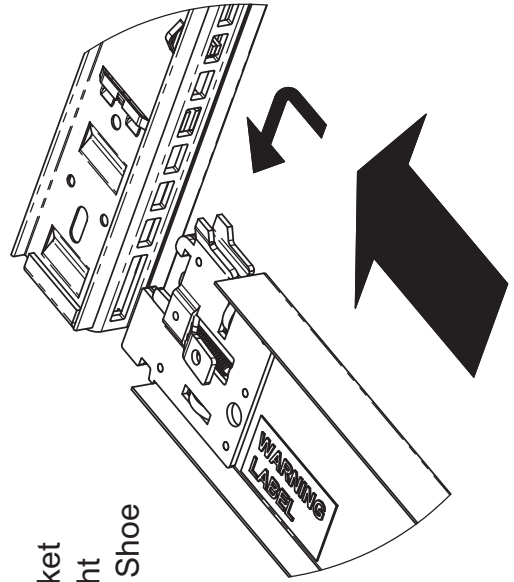

Slider will **CLICK** if properly installed

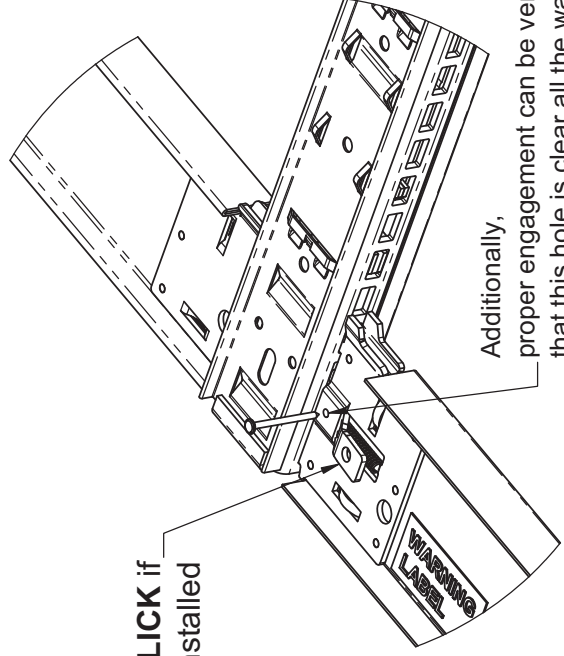

Additionally, proper engagement can be verified by making sure that this hole is clear all the way through the Shoe. Use WSRP pin to check.

STEP 5 Install Lower Spanner on the lowest lance of the Upright

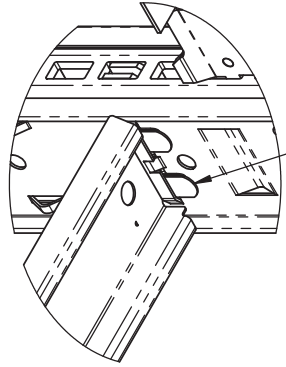
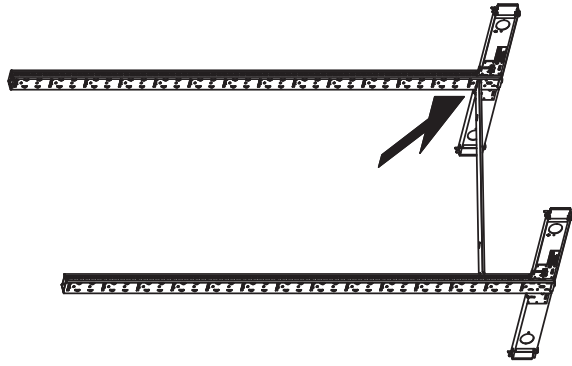

Both Spanner tabs must be showing below lances

STEP 6 Install Center Spanner at approximate midpoint of Back

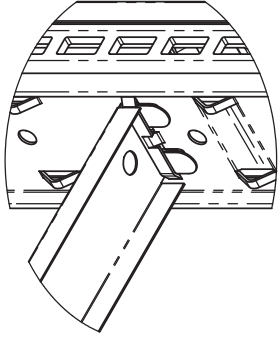
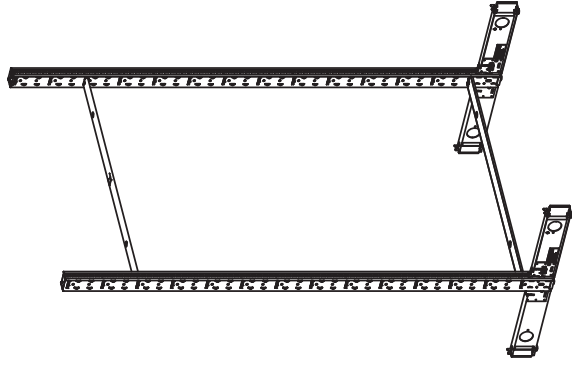

STEP 7 Install the Back panel. Slide down from top onto the Lower Spanner.

CAUTION!
Do not drop Backs. It may result in damage to the Lower Spanner.



WARNING!
Never allow framework to stand alone until a Back panel is in place. **Framework may fall and may cause injury or damage components!** Center & Bottom Spanners must be installed.

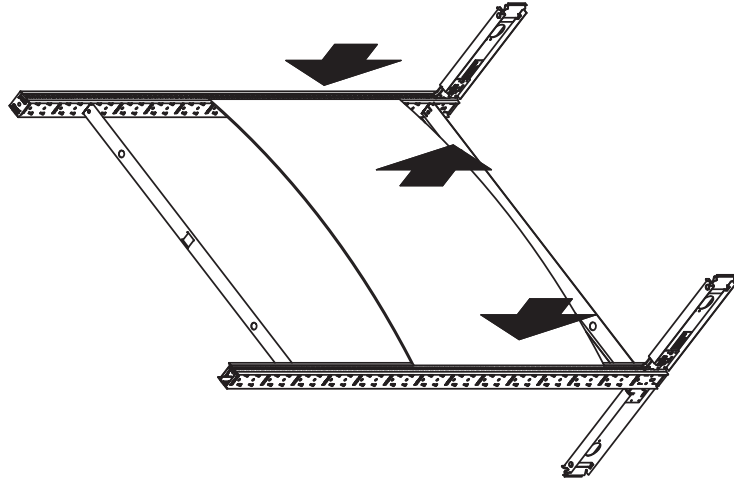

If low ceiling clearance prevents installation of Back panels from top, Back panels may be bowed slightly and flexed into Uprights.

Be careful not to damage Back panels.

STEP 8 Stand remaining Uprights in run, installing Center and Lower Spanners between the Uprights.

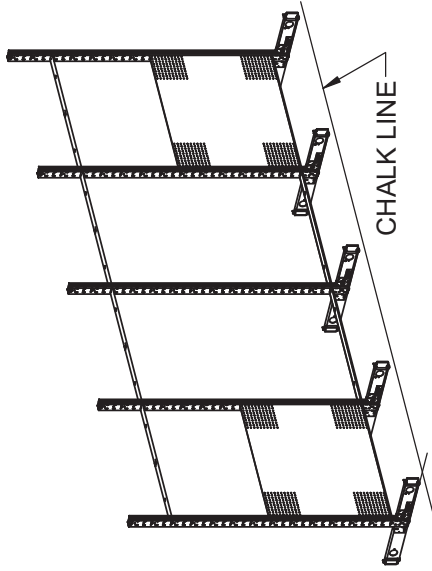

CHALK LINE

If run is 8 sections or less, install one Back into first and last sections to square before leveling. If gondola is more than 8 sections then additional Back(s) will need to be installed in center of run for additional stability.

STEP 9 Install all Kick Plates. Either snap in from the front or slide down from the top

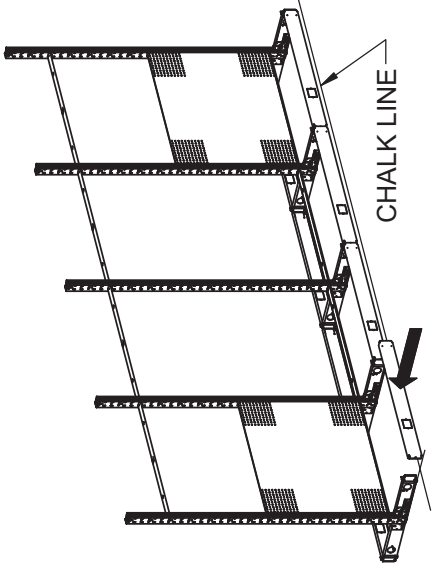

CHALK LINE

STEP 10

Raise both end Uprights using Base Shoe levelers approximately 1/2" and **plumb** Uprights with magnetic level against the face of the Upright. Both ends should be at the same height.

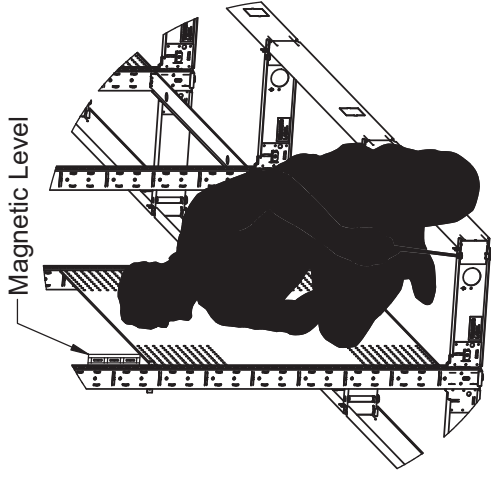

Magnetic Level

WHAT IS PLUMB?

Use magnetic level against Upright face to verify

90°

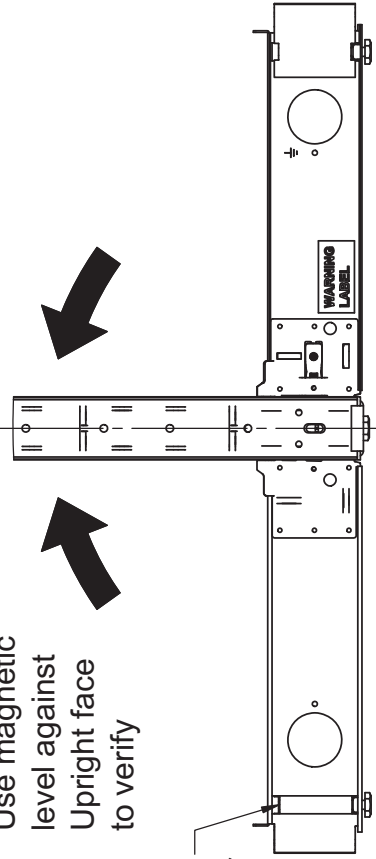

Adjust Shoe leg with screw driver

SCALE 1 : 16

BASE SHOE LEVELER LEGS

Use shims if needed

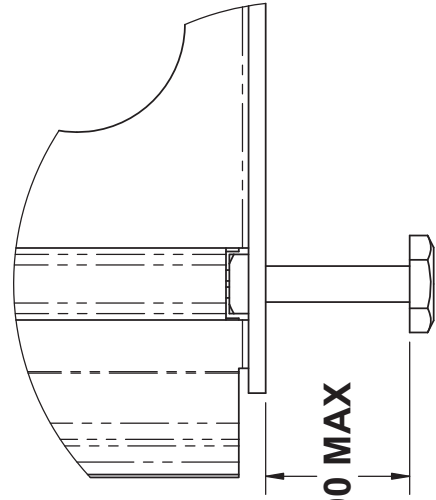

1.500 MAX

SCALE 1 : 3

STEP 11 Attach the nylon string to end Upright with GWSIK as shown. Attach line at corresponding slot on opposite end Upright. Draw taut and secure

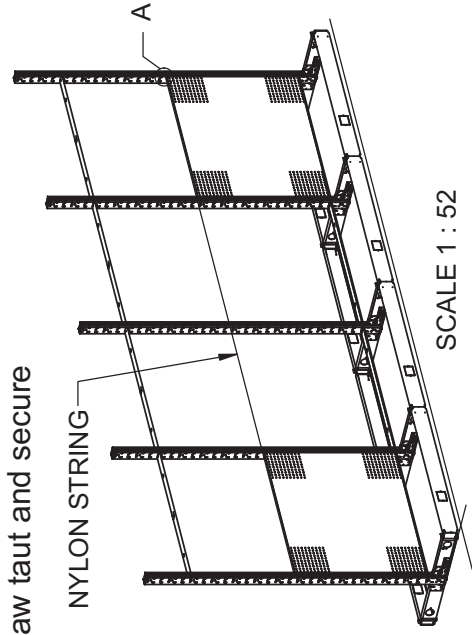

SCALE 1 : 52

Customer must specifically order Gondola / Wall Section Installation Kit (GWSIK) . It includes nylon string & bars to anchor string.

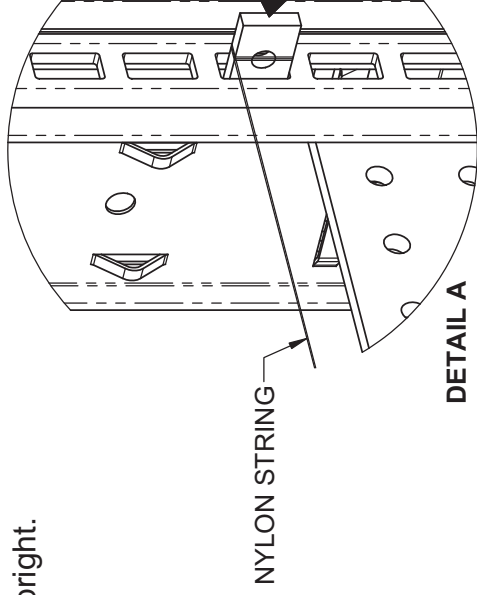

DETAIL A
SCALE 1 : 2

STEP 12 Examine all center Uprights at nylon string to determine the highest Upright in the run. If the highest Upright is below the string line then bring it up to the stringline using the Base Shoe levelers and **plumb**. If it is above the string line it will be necessary to go back and raise both the end Uprights to match that high spot.

STEP 13 Now raise and **plumb** the remaining Uprights in succession to match the string line using the Base Shoe levelers and using a magnetic level against the face of the Upright. Make sure Kick Plates are on chalkline and all Base Shoe leveler legs are touching the floor.

IMPORTANT! (for 2-sided Gondola) Upright leveler legs must be 1/8" off the floor. This will prevent a "high" center gondola that is unstable.

**UPRIGHT
LEG ONLY**

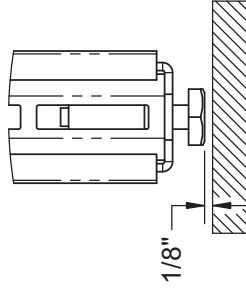

SLOT ALIGNMENT

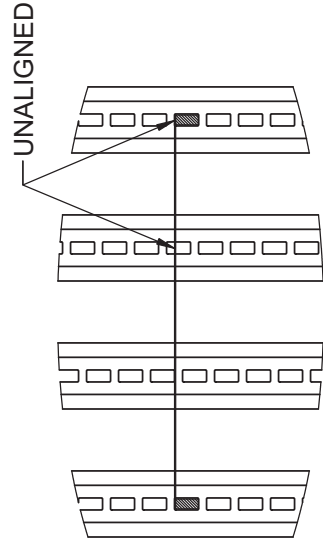

BEFORE

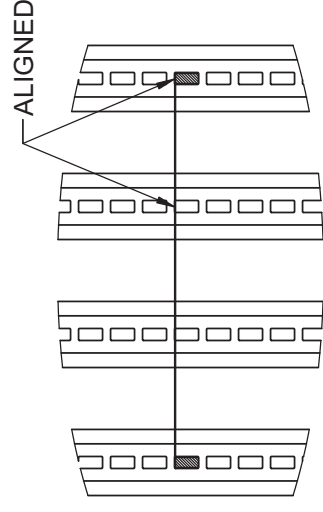

AFTER

<p>STEP 14 Install Floor Anchors if required.</p> <p>STEP 15 Remove the nylon string and install all lower Back panels in the run.</p> <p>STEP 16 Install Splicer Spanners in lances between upper and lower Back if a 2-piece Backs are required.</p> <p>STEP 17 Install remaining upper Back panels.</p> <p>STEP 18 Install Top Spanners. Make sure locking tabs rest below first lance as shown.</p> <p>STEP 19 Install Upright End Covers. Hook over top of Upright, then press on working toward the floor. UEC is vinyl and VC is metal.</p> <p>STEP 20 For Uprights 66" or shorter, install Upright Caps so that the short plastic extrusion is captured in the slot at top of the Upright End Cover while tabs snap behind top lance.</p> <p>STEP 21 Install the Base End Covers over the Base Shoes so the Shoe tab is through slot in the Cover.</p>	<p>Regular Duty Floor Anchor (SFA-RD)</p> <p>Heavy Duty Floor Anchor (SFA-HDGAL)</p> <p>Review ASY-357 for Floor Anchor instructions. The type of Anchor is based on the need for the location as it relates to seismic requirements. In addition, if the Upright to Base Shoe ratio exceeds 6 : 1, then Floor Anchors are recommended.</p> <p>STEP 14</p>	<p>TOP SPANNER (STL)</p> <p>LOCKING TABS ENGAGE TOP LANCE</p> <p>STEP 18</p>	<p>UPRIGHT CAP (UC) for Uprights 66" tall or less</p> <p>UPRIGHT END COVER (UEC/VC)</p> <p>STEP 19 & 20</p>
<p>STEP 22 Install Base Shelves. Engage shelf bracket into the lowest Upright slot available and rest on top of Base Shoes.</p> <p>STEP 23 Install Upper Shelves and all accessories (not shown).</p>	<p>CAUTION! DO NOT DROP BACKS MAY DAMAGE SPANNERS</p> <p>Shoe tab to retain Cover</p> <p>STEP 21</p>	<p>STEP 21</p>	<p>STEP 22</p>
<p>STEP 22 Install Base Shelves. Engage shelf bracket into the lowest Upright slot available and rest on top of Base Shoes.</p> <p>STEP 23 Install Upper Shelves and all accessories (not shown).</p>	<p>STEP 22 Install Base Shelves. Engage shelf bracket into the lowest Upright slot available and rest on top of Base Shoes.</p> <p>STEP 23 Install Upper Shelves and all accessories (not shown).</p>	<p>STEP 23</p>	<p>STEP 22 Install Base Shelves. Engage shelf bracket into the lowest Upright slot available and rest on top of Base Shoes.</p> <p>STEP 23 Install Upper Shelves and all accessories (not shown).</p>

RELEVEL & REPLUMB GONDOLA RUNS

***WARNING*:** Before proceeding, assure that no sections in the run exceed the maximum allowable merchandise load. Refer to ASY-046, pages 5-7 for fixture loading detail

***WARNING*:** If upright height or alignment adjustments are required, due to improper installation, all merchandise must be removed from the gondola run.

I. How to check to make sure that the fixture is leveled and aligned properly:

1. Make sure that the fixture is completely unloaded
2. Standing on a ladder, visually sight across the top of the uprights to check for vertical alignment.
3. If vertical misalignment between uprights can be seen, tie a string line from one end of the run to the other and observe which uprights are high and which ones are low. Then, using the same string line, observe where the run is misaligned inward and outward.
4. Wherever these conditions exist, relevel the runs in accordance with Steps 13 through 23

II. Re-plumbing heavily loaded sections:

Sometimes fixtures can get out of alignment after being loaded with merchandise. This is because some sections within the run are more heavily loaded than others. If, after merchandising a run, gaps between shelves can be seen, this is an indication of heavily loaded sections. The following procedure will describe how to re-plumb the fixture in this case.

***Warning*:** Never extend leveling legs on base shoes more than 1 1/2" as they can become unstable or disengaged

***Warning*:** Take extreme care NOT to place fingers or hand between the leveling legs and the floor as this could cause serious injury.

To re-plumb a section of gondola

1. Make sure the upright leveling legs are contacting the floor in the section being re-plumbed.
 2. On the lightly loaded side of the gondola, remove the kickplate at the upright being adjusted. **Caution: Only remove one kickplate at a time.**
 3. Next, on the lightly loaded side of the gondola, retract the base shoe leveling leg 1 to 3 turns depending on how severely the upright is leaning.
 4. Using a minimum of two people, go to the more heavily loaded side of the gondola. Have one person use a 48" long 2X4 board or similar device and push on the upright face toward the lightly loaded side to relieve pressure on the heavy side leveling leg.
 5. Then the other person should extend the base shoe leveling leg the same number of turns as the opposite side was retracted.
- Caution: Always extend or retract the leveling legs the same number of turns on both sides.**
- Caution: Never attempt to extend the heavy side leveler without first relieving the pressure on it.**
6. Once completed, use a carpenter's level to see if the upright is now properly plumbed. If not repeat the previous steps.
 7. Repeat each of these steps for every upright in the run that needs re-plumbing.
 8. Finally check to make sure that all levelers are contacting the floor and that all base shoes are bearing snugly against the upright face.