

EXTENDED SLATWALL PANEL

PAGE 1 OF 1
ASY1-296

INSTALLATION INSTRUCTIONS

1 Lay slatwall panel (SWDP) on clean surface face down and secure (3) brackets with provided screws as shown.

2 Locate crossbars (SWMB) at desired height, spaced 12" apart. Install panel assembly on crossbars.

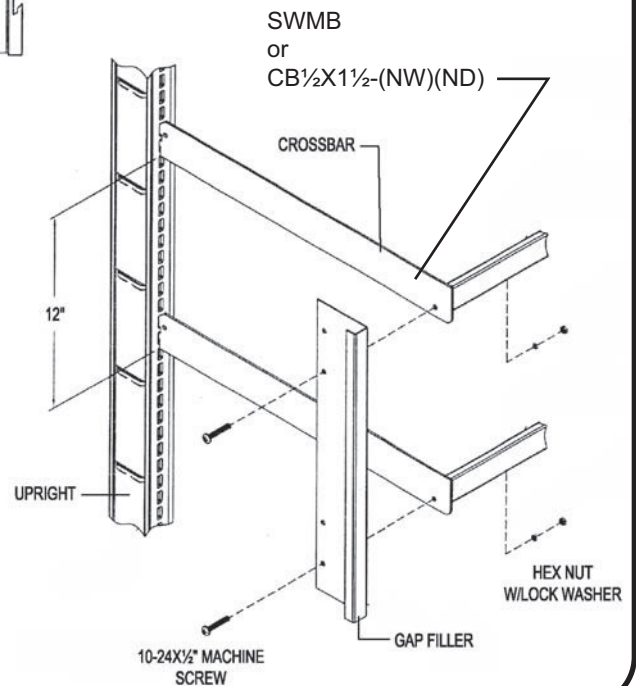
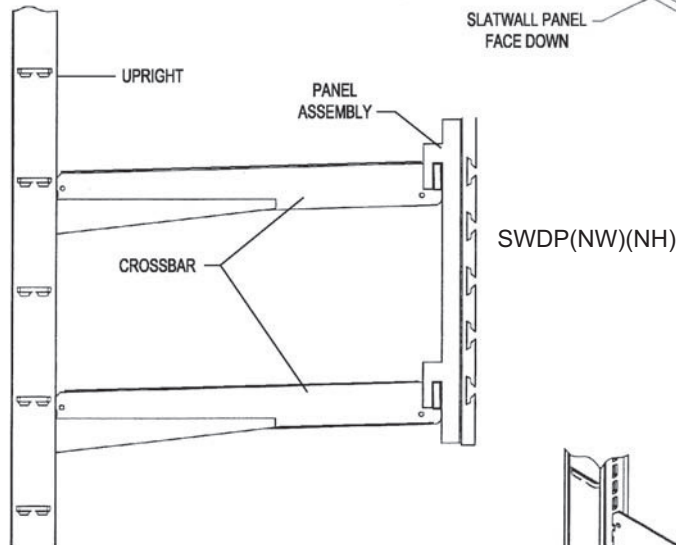
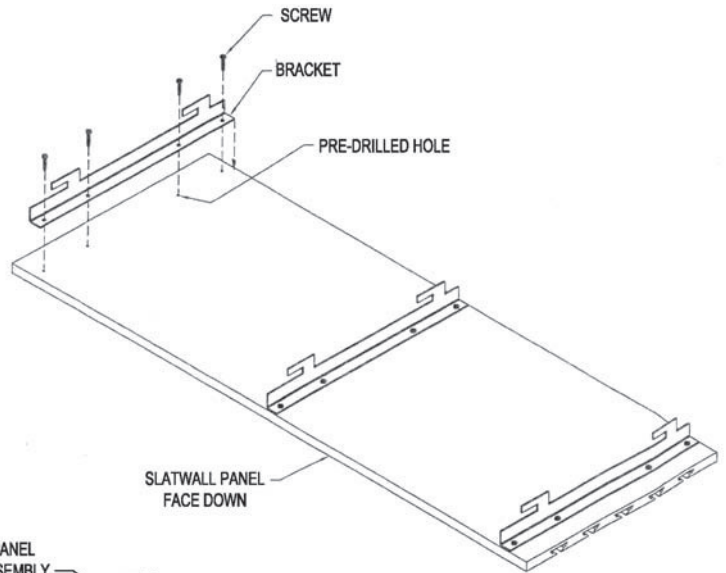

1 **GAP FILLERS:** Align gap fillers (SWDPGF) with slatwall panel and use provided hardware to secure to crossbars. Gap filler reverse for RH/LH use.

madix™
STORE FIXTURES

P.O. BOX 729 / TERRELL, TEXAS 75160 / 972.563.5744 / 800.776.2349
P.O. BOX 177 / GOODWATER, ALABAMA 35072 / 205.839.6354 / 800.633.6282

REV

REV#	ECN#	REVISION	BY	DATE	REV#	ECN#	REVISION	BY	DATE
	AL3975		AJB	8/16/05					